

// Essex: Master Proof //
Modern Industrial Color Scheme

Typefaces

Museo Sans - 300

ABCDEFGHIJKLMNOPQRSTUVWXYZ | 0123456789

Museo Sans - 500

ABCDEFGHIJKLMNOPQRSTUVWXYZ | 0123456789

Project Color and Finishes



Color Family: Modern Industrial

Color Palette is based on Essex Signage Standards and was chosen for this property with consideration of the property building colors and architecture, existing signage, and regional location.

Visibility Chart (For Reference)

Letter Visibility	Viewing Distance
1" - 2"	5' - 50'
2" - 4"	50' - 100'
4" - 8"	100' - 200'

ADA Mounting Requirements

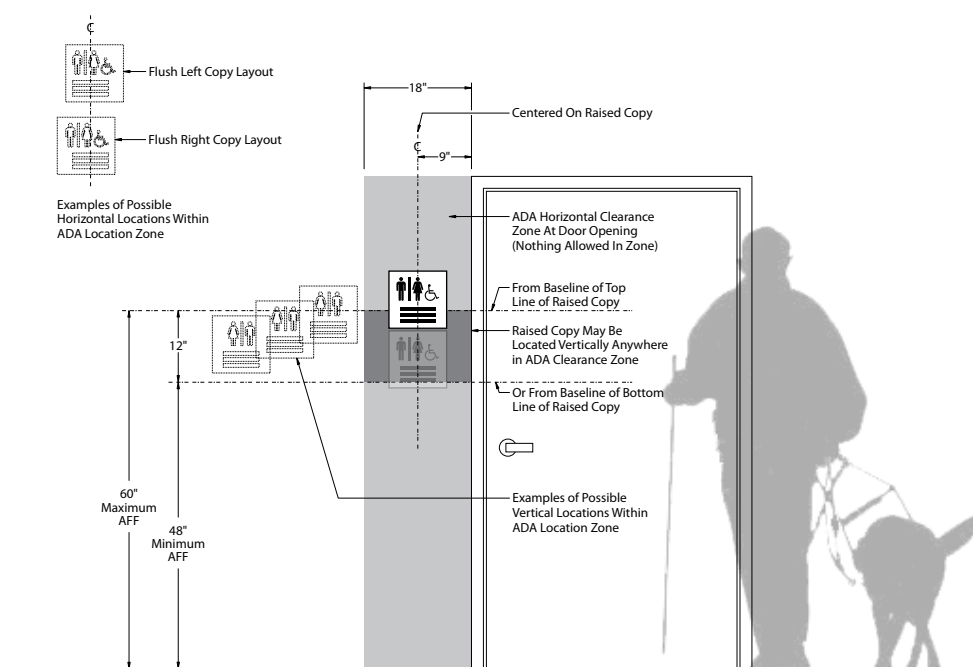

Table of Contents

Sign Type A	Building Address	Sign Type II	Fire Extinguisher
Sign Type B	Monument	Sign Type JJ	Handicap Sign
Sign Type C	Leasing Center Canopy	Sign Type KK	Electric Vehicle
Sign Type D	Leasing Hours	Sign Type LL	Emergency Shut-Off
Sign Type E	Amenity ID/Hours		
Sign Type F	Future Resident		
Sign Type G	Resident Guest Parking		
Sign Type H	Site Map		
Sign Type I	Restroom Signs		
Sign Type J	Exit Signs		
Sign Type K	Egress		
Sign Type L	Star Landing		
Sign Type M	In Case of Fire		
Sign Type N	Evac Plan		
Sign Type M	Unit ID		
Sign Type N	Exterior Unit ID		
Sign Type O	Unit Range Interior		
Sign Type P	Building ID		
Sign Type Q	Carport/Garage/Storage ID		
Sign Type R	Utility ID		
Sign Type S	Maximum Occupancy		
Sign Type T	Directional Exterior		
Sign Type U	Lot Entry		
Sign Type V	Clearance Bar		
Sign Type W	Clearance Bar - Directional		
Sign Type X	Large Rules		
Sign Type Y	Small Rules		
Sign Type Z	Spa Rules		
Sign Type AA	Pool Rules		
Sign Type BB	Pool Warning		
Sign Type CC	Pool Gate Closed		
Sign Type DD	Prop 65		
Sign Type EE	Call Box Sign		
Sign Type FF	Elevator Sign		
Sign Type GG	Resident Entrance Only		
Sign Type HH	Handicap Symbol		

Activity Log

Date	Description
7/1/16	Setup
7/20/16	Changes
8/15/16	Changes
9/20/16	Changes
4/26/17	Changes

6195 Shiloh Road
Suite A
Alpharetta, GA 30005

800-737-4434
yourbenson.com

Benson is a trade name of Benson Media, Inc. All ideas, designs and plans indicated or represented by this drawing are the property of Benson and were created and developed for use in connection with the specified project. They are not to be used, reproduced or copied in whole or in part and shall be returned upon request. None of such ideas, designs or plans shall be used by or disclosed to any persons, firms or corporations for any purpose whatsoever without the written consent of Benson. Copyright © Benson 2015. All rights reserved.

Client

Essex

Project

Signage Master Proof

Job Number

246199

Project Address

Artist Acct Director

M.Bando K.Daniel

Colors & Finishes

Colors displayed in this PDF proof are a close representation, but may not be an accurate depiction of final printed/painted/fabricated product. Client to either provide samples or specifications or approve Benson color samples or specifications prior to production.

Modern Industrial

[C1] PMS 445	[C2] PMS 420	[C3] White
[C4] Black	[C5] PMS	

Benson is not responsible for errors or omissions after your proof is approved. Please note that production of this order will not start until all layouts are approved. Proofing is designed to reduce your final cost. Please examine carefully for any errors. Once approved, you are responsible for any and all cost to remake should any errors be found after production begins, no exceptions. You agree to these terms and art approval of the layouts by signing below.

Customer Approval

Proof Approval	AD/CSC	Production
QC Check		Ship: --/-- Install: --/--

Scale	Sheet
As Noted	Details



1 FRONT ELEVATION
A.01 Scale: 1 1/2" = 1'

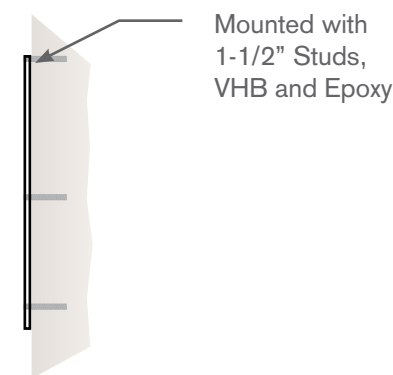

2 SIDE ELEVATION
A.01 Scale: 1 1/2" = 1'

Notes

6195 Shiloh Road
Suite A
Alpharetta, GA 30005

800-737-4434
yourbenson.com

Benson is a trade name of Benson Media, Inc. All ideas, designs and plans indicated or represented by this drawing are the property of Benson and were created and developed for use in connection with the specified project. They are not to be used, reproduced or copied in whole or in part and shall be returned upon request. None of such ideas, designs or plans shall be used by or disclosed to any persons, firms or corporations for any purpose whatsoever without the written consent of Benson. Copyright © Benson 2015. All rights reserved.

Client

Essex

Project

Signage Master Proof

Job Number

246199

Project Address

Artist **Acct Director**

M.Bando K.Daniel

Colors & Finishes

Colors displayed in this PDF proof are a close representation, but may not be an accurate depiction of final printed/painted/fabricated product. Client to either provide samples or specifications or approve Benson color samples or specifications prior to production.

Modern Industrial

[C1] PMS 445	[C2] PMS 420	[C3] White
[C4] Black	[C5] PMS	

Benson is not responsible for errors or omissions after your proof is approved. Please note that production of this order will not start until all layouts are approved. Proofing is designed to reduce your final cost. Please examine carefully for any errors. Once approved, you are responsible for any and all cost to remake should any errors be found after production begins, no exceptions. You agree to these terms and art approval of the layouts by signing below.

Customer Approval		
Proof Approval	AD/CSC	Production
QC Check		Ship: --/-- Install: --/--
Scale	Sheet	
As Noted	A.01	



1 FRONT ELEVATION
B.01 Scale: NTS

DESIGN NOTES:

- Monument will be a cabinet with small accents in the accent color.
- The Property name will be in dimensional lettering and the depth can be increased or decreased to insure visibility and impact on drive by traffic.
- This cabinet can also be in many different sizes. Very versatile.
- Monument base is streamlined and can be adjusted to any grade.

Notes

Sizing and Mounting Vary from location to location.

6195 Shiloh Road
 Suite A
 Alpharetta, GA 30005

800-737-4434
 yourbenson.com

Benson is a trade name of Benson Media, Inc. All ideas, designs and plans indicated or represented by this drawing are the property of Benson and were created and developed for use in connection with the specified project. They are not to be used, reproduced or copied in whole or in part and shall be returned upon request. None of such ideas, designs or plans shall be used by or disclosed to any persons, firms or corporations for any purpose whatsoever without the written consent of Benson. Copyright © Benson 2015. All rights reserved.

Client	
Essex	
Project	
Signage Master Proof	
Job Number	
246199	
Project Address	
Artist	Acct Director
M.Bando	K.Daniel
Colors & Finishes	
<small>Colors displayed in this PDF proof are a close representation, but may not be an accurate depiction of final printed/painted/fabricated product. Client to either provide samples or specifications or approve Benson color samples or specifications prior to production.</small>	
Modern Industrial	
[C1] PMS 445	[C2] PMS 420
[C3] White	[C4] Black
[C5] PMS	
<small>Benson is not responsible for errors or omissions after your proof is approved. Please note that production of this order will not start until all layouts are approved. Proofing is designed to reduce your final cost. Please examine carefully for any errors. Once approved, you are responsible for any and all cost to remake should any errors be found after production begins, no exceptions. You agree to these terms and art approval of the layouts by signing below.</small>	
Customer Approval	
Proof Approval	AD/CSC Production
QC Check	Ship: --/-- Install: --/--
Scale	Sheet
As Noted	B.01



1 FRONT ELEVATION
B.01 Scale: NTS

DESIGN NOTES:

- Monument will be a cabinet with small accents in the accent color.
- The Property name will be in dimensional lettering and the depth can be increased or decreased to insure visibility and impact on drive by traffic.
- This cabinet can also be in many different sizes. Very versatile.
- Monument base is streamlined and can be adjusted to any grade.

Notes

Sizing and Mounting Vary from location to location.

6195 Shiloh Road
 Suite A
 Alpharetta, GA 30005

800-737-4434
 yourbenson.com

Benson is a trade name of Benson Media, Inc. All ideas, designs and plans indicated or represented by this drawing are the property of Benson and were created and developed for use in connection with the specified project. They are not to be used, reproduced or copied in whole or in part and shall be returned upon request. None of such ideas, designs or plans shall be used by or disclosed to any persons, firms or corporations for any purpose whatsoever without the written consent of Benson. Copyright © Benson 2015. All rights reserved.

Client	
Essex	
Project	
Signage Master Proof	
Job Number	
246199	
Project Address	
Artist	Acct Director
M.Bando	K.Daniel
Colors & Finishes	
<small>Colors displayed in this PDF proof are a close representation, but may not be an accurate depiction of final printed/painted/fabricated product. Client to either provide samples or specifications or approve Benson color samples or specifications prior to production.</small>	
Modern Industrial	
[C1] PMS 445	[C2] PMS 420
[C3] White	[C4] Black
[C5] PMS	
<small>Benson is not responsible for errors or omissions after your proof is approved. Please note that production of this order will not start until all layouts are approved. Proofing is designed to reduce your final cost. Please examine carefully for any errors. Once approved, you are responsible for any and all cost to remake should any errors be found after production begins, no exceptions. You agree to these terms and art approval of the layouts by signing below.</small>	
Customer Approval	
Proof Approval	AD/CSC Production
QC Check	Ship: --/-- Install: --/--
Scale	Sheet
As Noted	B.01



1 FRONT ELEVATION
FF.01 Scale: 1" = 1'

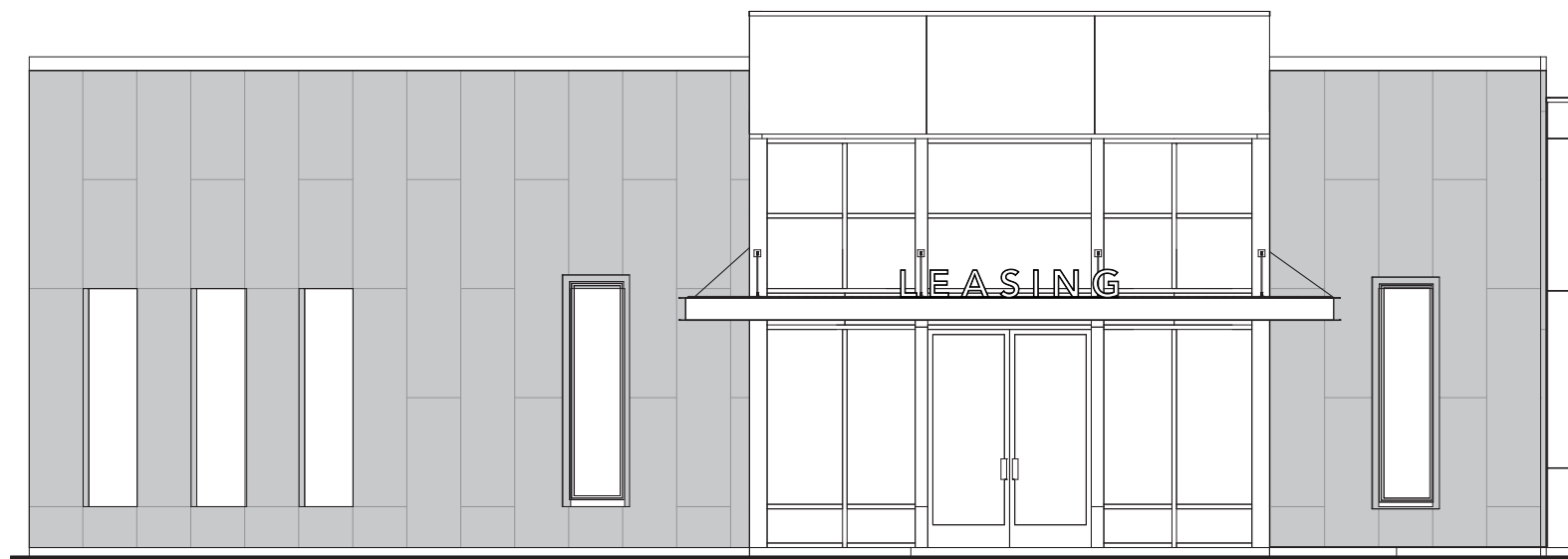

Notes

Size and Mounting May Vary

6195 Shiloh Road
Suite A
Alpharetta, GA 30005

800-737-4434
yourbenson.com

Benson is a trade name of Benson Media, Inc. All ideas, designs and plans indicated or represented by this drawing are the property of Benson and were created and developed for use in connection with the specified project. They are not to be used, reproduced or copied in whole or in part and shall be returned upon request. None of such ideas, designs or plans shall be used by or disclosed to any persons, firms or corporations for any purpose whatsoever without the written consent of Benson. Copyright © Benson 2015. All rights reserved.

Client

Essex

Project

Signage Master Proof

Job Number

246199

Project Address

Artist **Acct Director**

M.Bando K.Daniel

Colors & Finishes

Colors displayed in this PDF proof are a close representation, but may not be an accurate depiction of final printed/painted/fabricated product. Client to either provide samples or specifications or approve Benson color samples or specifications prior to production.

Modern Industrial

[C1] PMS 445	[C2] PMS 420	[C3] White
[C4] Black	[C5] PMS	

Benson is not responsible for errors or omissions after your proof is approved. Please note that production of this order will not start until all layouts are approved. Proofing is designed to reduce your final cost. Please examine carefully for any errors. Once approved, you are responsible for any and all cost to remake should any errors be found after production begins, no exceptions. You agree to these terms and art approval of the layouts by signing below.

Customer Approval		
Proof Approval	AD/CSC	Production
QC Check		Ship: --/-- Install: --/--
Scale	Sheet	
As Noted	C.01	

COMMUNITY NAME

C3 Painted 3" Deep Fabricated Channel Letter

1 FRONT ELEVATION
C.01 Scale: NTS



Notes

Size and Mounting May Vary

6195 Shiloh Road
Suite A
Alpharetta, GA 30005

800-737-4434
yourbenson.com

Benson is a trade name of Benson Media, Inc. All ideas, designs and plans indicated or represented by this drawing are the property of Benson and were created and developed for use in connection with the specified project. They are not to be used, reproduced or copied in whole or in part and shall be returned upon request. None of such ideas, designs or plans shall be used by or disclosed to any persons, firms or corporations for any purpose whatsoever without the written consent of Benson. Copyright © Benson 2015. All rights reserved.

Client	
Essex	
Project	
Signage Master Proof	
Job Number	
246199	
Project Address	
Artist	Acct Director
M.Bando	K.Daniel
Colors & Finishes	
<small>Colors displayed in this PDF proof are a close representation, but may not be an accurate depiction of final printed/painted/fabricated product. Client to either provide samples or specifications or approve Benson color samples or specifications prior to production.</small>	
Modern Industrial	
[C1] PMS 445	[C2] PMS 420
[C3] White	[C4] Black
[C5] PMS	
<small>Benson is not responsible for errors or omissions after your proof is approved. Please note that production of this order will not start until all layouts are approved. Proofing is designed to reduce your final cost. Please examine carefully for any errors. Once approved, you are responsible for any and all cost to remake should any errors be found after production begins, no exceptions. You agree to these terms and art approval of the layouts by signing below.</small>	
Customer Approval	
Proof Approval	AD/CSC
QC Check	Production
	Ship: --/-- Install: --/--
Scale	Sheet
As Noted	C.01



Community Name

C3 Plotted Vinyl Graphics

LEASING OFFICE

000-000-0000

HOURS

00 am to 00 pm
Daily

Maintenance: 000.000.0000

1 FRONT ELEVATION
D.01 Scale: NTS

Notes

Size Varies on Door/Glass Size

6195 Shiloh Road
Suite A
Alpharetta, GA 30005

800-737-4434
yourbenson.com

Benson is a trade name of Benson Media, Inc. All ideas, designs and plans indicated or represented by this drawing are the property of Benson and were created and developed for use in connection with the specified project. They are not to be used, reproduced or copied in whole or in part and shall be returned upon request. None of such ideas, designs or plans shall be used by or disclosed to any persons, firms or corporations for any purpose whatsoever without the written consent of Benson. Copyright © Benson 2015. All rights reserved.

Client	
Essex	
Project	
Signage Master Proof	
Job Number	
246199	
Project Address	
Artist	Acct Director
M.Bando	K.Daniel
Colors & Finishes	
<small>Colors displayed in this PDF proof are a close representation, but may not be an accurate depiction of final printed/painted/fabricated product. Client to either provide samples or specifications or approve Benson color samples or specifications prior to production.</small>	
Modern Industrial	
[C1] PMS 445	[C2] PMS 420
[C3] White	[C4] Black
[C5] PMS	
<small>Benson is not responsible for errors or omissions after your proof is approved. Please note that production of this order will not start until all layouts are approved. Proofing is designed to reduce your final cost. Please examine carefully for any errors. Once approved, you are responsible for any and all cost to remake should any errors be found after production begins, no exceptions. You agree to these terms and art approval of the layouts by signing below.</small>	
Customer Approval	
Proof Approval	AD/CSC Production
QC Check	Ship: --/-- Install: --/--
Scale	Sheet
As Noted	D.01

Community Name

FITNESS CENTER

HOURS
00 am to 00 pm
Daily

1 FRONT ELEVATION
E.01 Scale: NTS

Community Name ← C3 Plotted Vinyl Graphics

FITNESS CENTER

Notes

Size Varies on Door/Glass Size

6195 Shiloh Road Suite A Alpharetta, GA 30005	
800-737-4434 yourbenson.com	
<small>Benson is a trade name of Benson Media, Inc. All ideas, designs and plans indicated or represented by this drawing are the property of Benson and were created and developed for use in connection with the specified project. They are not to be used, reproduced or copied in whole or in part and shall be returned upon request. None of such ideas, designs or plans shall be used by or disclosed to any persons, firms or corporations for any purpose whatsoever without the written consent of Benson. Copyright © Benson 2015. All rights reserved.</small>	
Client	
Essex	
Project	
Signage Master Proof	
Job Number	
246199	
Project Address	
Artist	Acct Director
M.Bando	K.Daniel
Colors & Finishes	
<small>Colors displayed in this PDF proof are a close representation, but may not be an accurate depiction of final printed/painted/fabricated product. Client to either provide samples or specifications or approve Benson color samples or specifications prior to production.</small>	
Modern Industrial	
[C1] PMS 445	[C2] PMS 420
[C3] White	
[C4] Black	[C5] PMS
<small>Benson is not responsible for errors or omissions after your proof is approved. Please note that production of this order will not start until all layouts are approved. Proofing is designed to reduce your final cost. Please examine carefully for any errors. Once approved, you are responsible for any and all cost to remake should any errors be found after production begins, no exceptions. You agree to these terms and art approval of the layouts by signing below.</small>	
Customer Approval	
Proof Approval	AD/CSC Production
QC Check	Ship: --/-- Install: --/--
Scale	Sheet
As Noted	E.01



Dibond Aluminum Composite Panel With First Surface Applied Digital Print With Protective Matte Laminate



Mounted with 1-1/2" Studs, VHB and Epoxy

1 FRONT ELEVATION
F.01 Scale: 2" = 1'

2 SIDE ELEVATION
F.01 Scale: 2" = 1'

Notes

Mounting varies.

6195 Shiloh Road
Suite A
Alpharetta, GA 30005

800-737-4434
yourbenson.com

Benson is a trade name of Benson Media, Inc. All ideas, designs and plans indicated or represented by this drawing are the property of Benson and were created and developed for use in connection with the specified project. They are not to be used, reproduced or copied in whole or in part and shall be returned upon request. None of such ideas, designs or plans shall be used by or disclosed to any persons, firms or corporations for any purpose whatsoever without the written consent of Benson. Copyright © Benson 2015. All rights reserved.

Client	
Essex	
Project	
Signage Master Proof	
Job Number	
246199	
Project Address	
Artist	Acct Director
M.Bando	K.Daniel
Colors & Finishes	
<small>Colors displayed in this PDF proof are a close representation, but may not be an accurate depiction of final printed/painted/fabricated product. Client to either provide samples or specifications or approve Benson color samples or specifications prior to production.</small>	
Modern Industrial	
[C1] PMS 445	[C2] PMS 420
[C4] Black	[C3] White
[C5] PMS	
<small>Benson is not responsible for errors or omissions after your proof is approved. Please note that production of this order will not start until all layouts are approved. Proofing is designed to reduce your final cost. Please examine carefully for any errors. Once approved, you are responsible for any and all cost to remake should any errors be found after production begins, no exceptions. You agree to these terms and art approval of the layouts by signing below.</small>	
Customer Approval	
Proof Approval	AD/CSC Production
QC Check	Ship: --/-- Install: --/--
Scale	Sheet
As Noted	F.01



Dibond Aluminum Composite Panel
With First Surface Applied Digital Print
With Protective Matte Laminate

1 FRONT ELEVATION
G.01 Scale: 1" = 1'

Notes

Mounting varies

6195 Shiloh Road Suite A Alpharetta, GA 30005	
800-737-4434 yourbenson.com	
<small>Benson is a trade name of Benson Media, Inc. All ideas, designs and plans indicated or represented by this drawing are the property of Benson and were created and developed for use in connection with the specified project. They are not to be used, reproduced or copied in whole or in part and shall be returned upon request. None of such ideas, designs or plans shall be used by or disclosed to any persons, firms or corporations for any purpose whatsoever without the written consent of Benson. Copyright © Benson 2015. All rights reserved.</small>	
Client	
Essex	
Project	
Signage Master Proof	
Job Number	
246199	
Project Address	
Artist	Acct Director
M.Bando	K.Daniel
Colors & Finishes	
<small>Colors displayed in this PDF proof are a close representation, but may not be an accurate depiction of final printed/painted/fabricated product. Client to either provide samples or specifications or approve Benson color samples or specifications prior to production.</small>	
Modern Industrial	
[C1] PMS 445	[C2] PMS 420
[C3] White	[C4] Black
[C5] PMS	
<small>Benson is not responsible for errors or omissions after your proof is approved. Please note that production of this order will not start until all layouts are approved. Proofing is designed to reduce your final cost. Please examine carefully for any errors. Once approved, you are responsible for any and all cost to remake should any errors be found after production begins, no exceptions. You agree to these terms and art approval of the layouts by signing below.</small>	
Customer Approval	
Proof Approval	AD/CSC Production
QC Check	Ship: --/-- Install: --/--
Scale	Sheet
As Noted	G.01



Dibond Aluminum Composite Panel With First Surface Applied Digital Print With Protective Matte Laminate

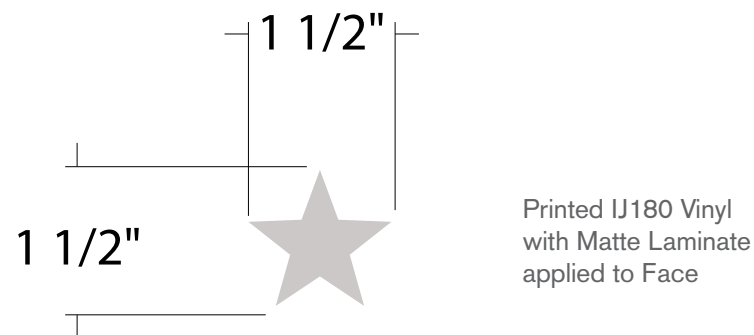

1 FRONT ELEVATION
H.01 Scale: 1" = 1'

2 YOU ARE HERE STICKER
H.01 Scale: NTS

Notes

Size, Mounting and Materials vary.

6195 Shiloh Road Suite A Alpharetta, GA 30005	
800-737-4434 yourbenson.com	
<small>Benson is a trade name of Benson Media, Inc. All ideas, designs and plans indicated or represented by this drawing are the property of Benson and were created and developed for use in connection with the specified project. They are not to be used, reproduced or copied in whole or in part and shall be returned upon request. None of such ideas, designs or plans shall be used by or disclosed to any persons, firms or corporations for any purpose whatsoever without the written consent of Benson. Copyright © Benson 2015. All rights reserved.</small>	
Client	
Essex	
Project	
Signage Master Proof	
Job Number	
246199	
Project Address	
Artist	Acct Director
M.Bando	K.Daniel
Colors & Finishes	
<small>Colors displayed in this PDF proof are a close representation, but may not be an accurate depiction of final printed/painted/fabricated product. Client to either provide samples or specifications or approve Benson color samples or specifications prior to production.</small>	
Modern Industrial	
[C1] PMS 445	[C2] PMS 420
[C4] Black	[C3] White
[C5] PMS	
<small>Benson is not responsible for errors or omissions after your proof is approved. Please note that production of this order will not start until all layouts are approved. Proofing is designed to reduce your final cost. Please examine carefully for any errors. Once approved, you are responsible for any and all cost to remake should any errors be found after production begins, no exceptions. You agree to these terms and art approval of the layouts by signing below.</small>	
Customer Approval	
Proof Approval	AD/CSC Production
QC Check	Ship: --/-- Install: --/--
Scale	Sheet
As Noted	H.01

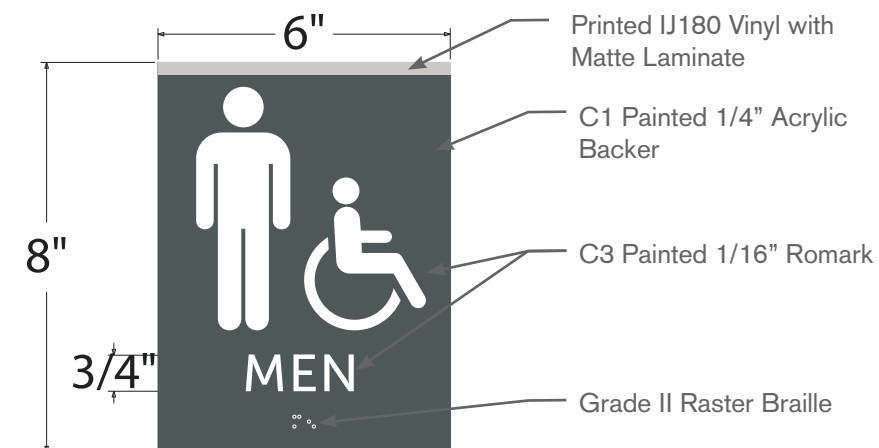
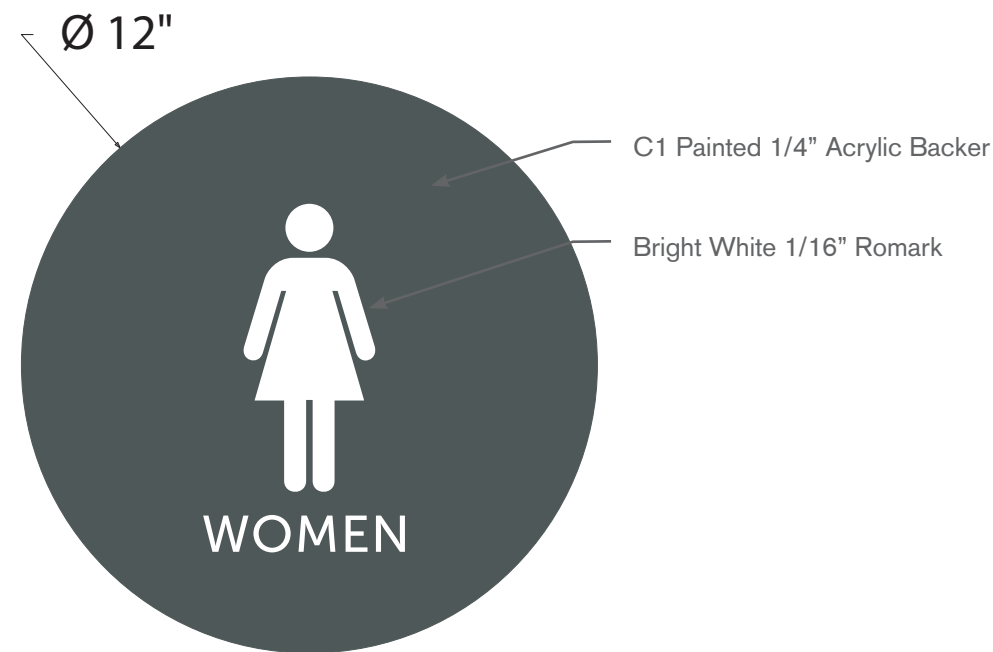
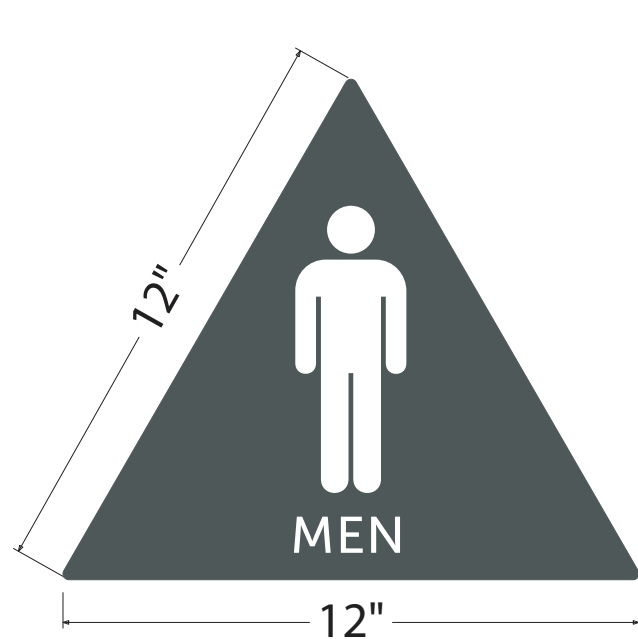

1 RESTROOM SET 1
I.01 Scale: 3" = 1'

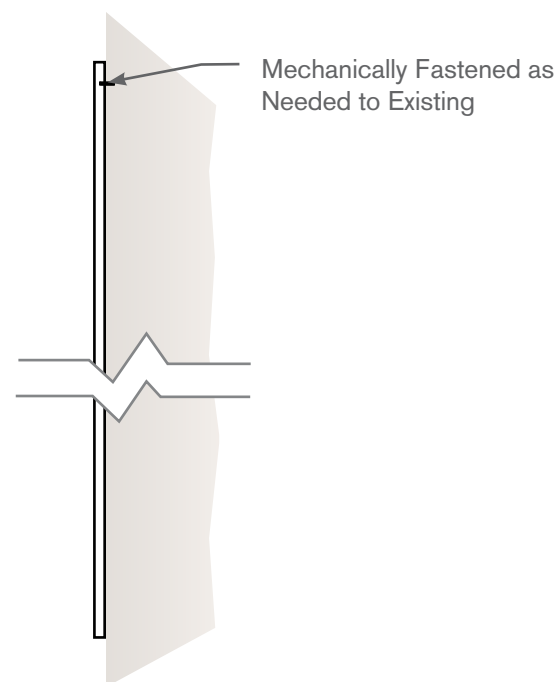

3 MOUNTING
I.01 TYPICAL

Notes

SIGNS NEEDED DEPEND ON STATE REGULATIONS.

COMPLETE LISTING ON NEXT PAGE.

6195 Shiloh Road Suite A Alpharetta, GA 30005		
800-737-4434 yourbenson.com		
<small>Benson is a trade name of Benson Media, Inc. All ideas, designs and plans indicated or represented by this drawing are the property of Benson and were created and developed for use in connection with the specified project. They are not to be used, reproduced or copied in whole or in part and shall be returned upon request. None of such ideas, designs or plans shall be used by or disclosed to any persons, firms or corporations for any purpose whatsoever without the written consent of Benson. Copyright © Benson 2015. All rights reserved.</small>		
Client		
Essex		
Project		
Signage Master Proof		
Job Number		
246199		
Project Address		
Artist	Acct Director	
M.Bando	K.Daniel	
Colors & Finishes		
<small>Colors displayed in this PDF proof are a close representation, but may not be an accurate depiction of final printed/painted/fabricated product. Client to either provide samples or specifications or approve Benson color samples or specifications prior to production.</small>		
Modern Industrial		
[C1] PMS 445	[C2] PMS 420	[C3] White
[C4] Black	[C5] PMS	
<small>Benson is not responsible for errors or omissions after your proof is approved. Please note that production of this order will not start until all layouts are approved. Proofing is designed to reduce your final cost. Please examine carefully for any errors. Once approved, you are responsible for any and all cost to remake should any errors be found after production begins, no exceptions. You agree to these terms and art approval of the layouts by signing below.</small>		
Customer Approval		
Proof Approval	AD/CSC	Production
QC Check		Ship: --/-- Install: --/--
Scale		Sheet
As Noted		I.01

SINGLE USE
SINGLE TOILET AND USER LOCKABLE DOOR

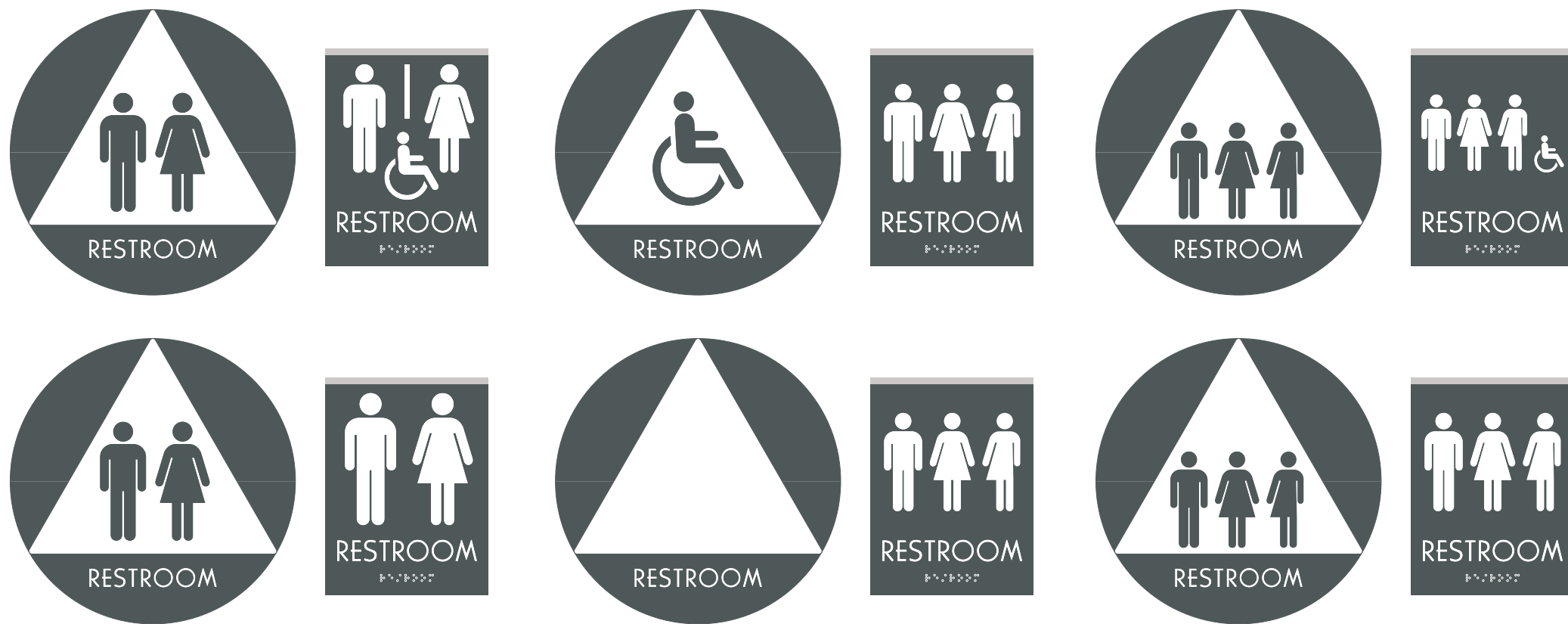

MULTIPLE USE
MULTIPLE STALLS AND/OR NON-LOCKABLE DOOR

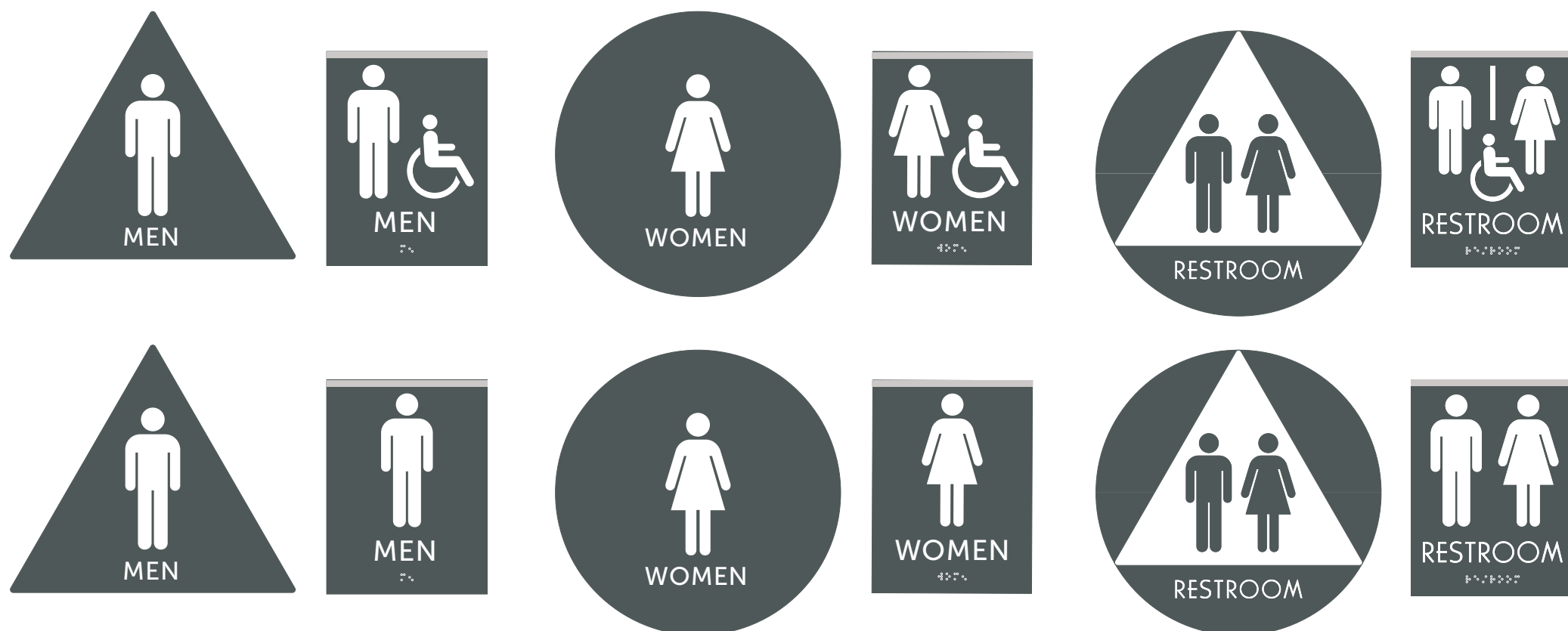

6195 Shiloh Road Suite A Alpharetta, GA 30005	
800-737-4434 yourbenson.com	
<small>Benson is a trade name of Benson Media, Inc. All ideas, designs and plans indicated or represented by this drawing are the property of Benson and were created and developed for use in connection with the specified project. They are not to be used, reproduced or copied in whole or in part and shall be returned upon request. None of such ideas, designs or plans shall be used by or disclosed to any persons, firms or corporations for any purpose whatsoever without the written consent of Benson. Copyright © Benson 2015. All rights reserved.</small>	
Client	
Essex	
Project	
Signage Master Proof	
Job Number	
246199	
Project Address	
Artist	Acct Director
M.Bando	K.Daniel
Colors & Finishes	
<small>Colors displayed in this PDF proof are a close representation, but may not be an accurate depiction of final printed/painted/fabricated product. Client to either provide samples or specifications or approve Benson color samples or specifications prior to production.</small>	
Modern Industrial	
[C1] PMS 445	[C2] PMS 420
[C3] White	[C4] Black
[C5] PMS	
<small>Benson is not responsible for errors or omissions after your proof is approved. Please note that production of this order will not start until all layouts are approved. Proofing is designed to reduce your final cost. Please examine carefully for any errors. Once approved, you are responsible for any and all cost to remake should any errors be found after production begins, no exceptions. You agree to these terms and art approval of the layouts by signing below.</small>	
Customer Approval	
Proof Approval	AD/CSC Production
QC Check	Ship: --/-- Install: --/--
Scale	Sheet
As Noted	1.01

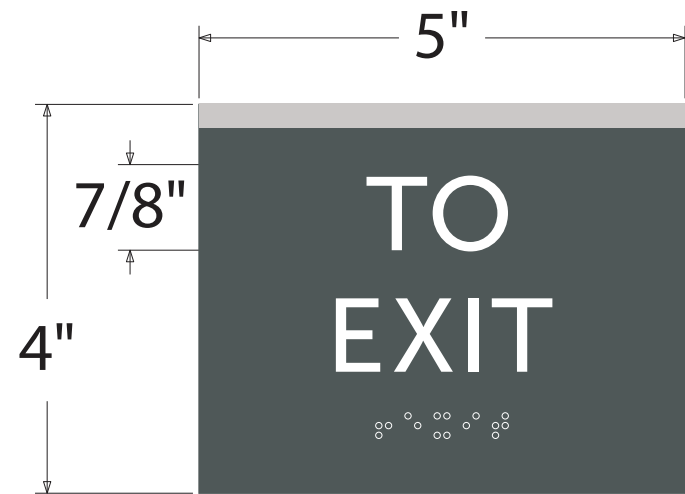
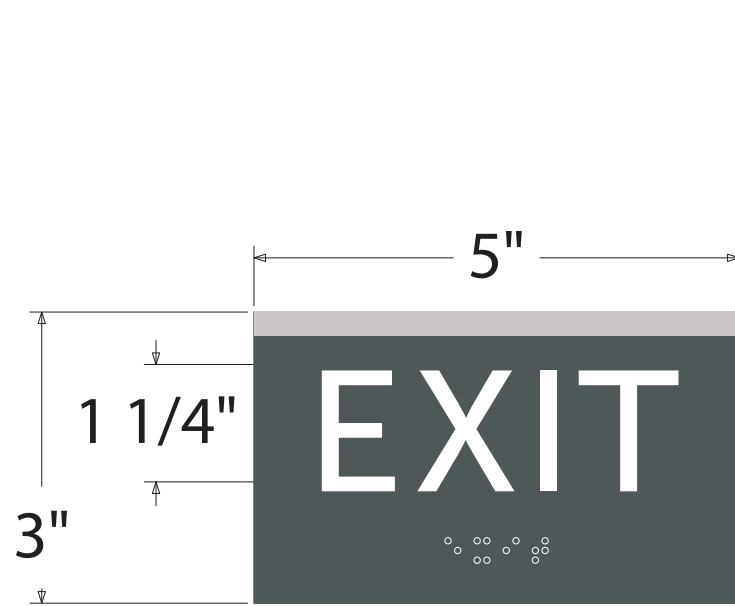

1 FRONT ELEVATION
J.01 Scale: 6" = 1'

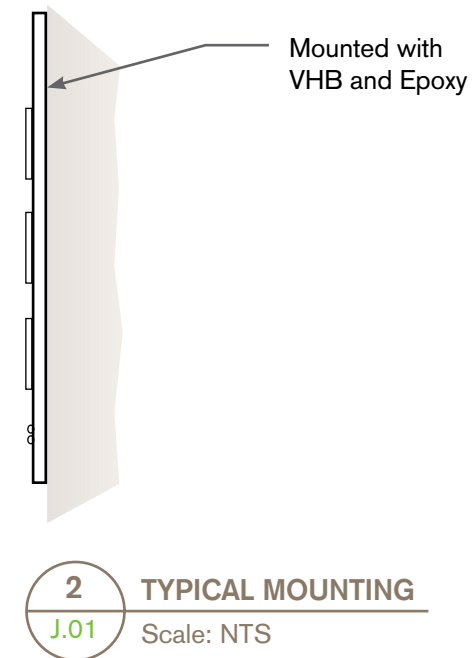
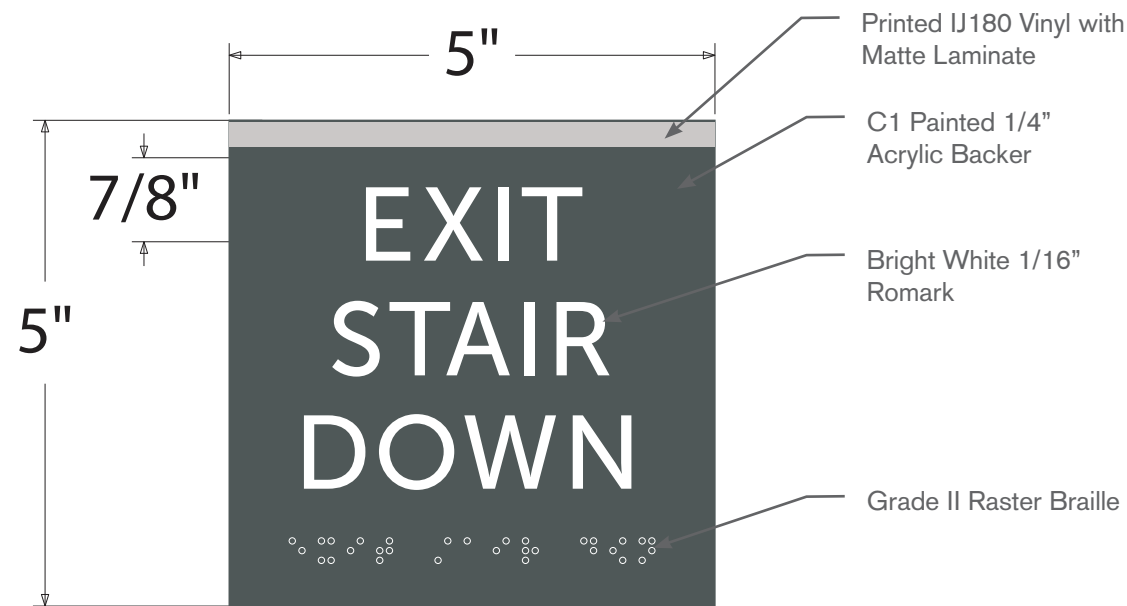

2 TYPICAL MOUNTING
J.01 Scale: NTS

Notes

6195 Shiloh Road
Suite A
Alpharetta, GA 30005

800-737-4434
yourbenson.com

Benson is a trade name of Benson Media, Inc. All ideas, designs and plans indicated or represented by this drawing are the property of Benson and were created and developed for use in connection with the specified project. They are not to be used, reproduced or copied in whole or in part and shall be returned upon request. None of such ideas, designs or plans shall be used by or disclosed to any persons, firms or corporations for any purpose whatsoever without the written consent of Benson. Copyright © Benson 2015. All rights reserved.

Client

Essex

Project

Signage Master Proof

Job Number

246199

Project Address

Artist **Acct Director**

M.Bando K.Daniel

Colors & Finishes

Colors displayed in this PDF proof are a close representation, but may not be an accurate depiction of final printed/painted/fabricated product. Client to either provide samples or specifications or approve Benson color samples or specifications prior to production.

Modern Industrial

[C1] PMS 445	[C2] PMS 420	[C3] White
[C4] Black	[C5] PMS	

Benson is not responsible for errors or omissions after your proof is approved. Please note that production of this order will not start until all layouts are approved. Proofing is designed to reduce your final cost. Please examine carefully for any errors. Once approved, you are responsible for any and all cost to remake should any errors be found after production begins, no exceptions. You agree to these terms and art approval of the layouts by signing below.

Customer Approval		
Proof Approval	AD/CSC	Production
QC Check		Ship: --/-- Install: --/--
Scale	Sheet	
As Noted	J.01	

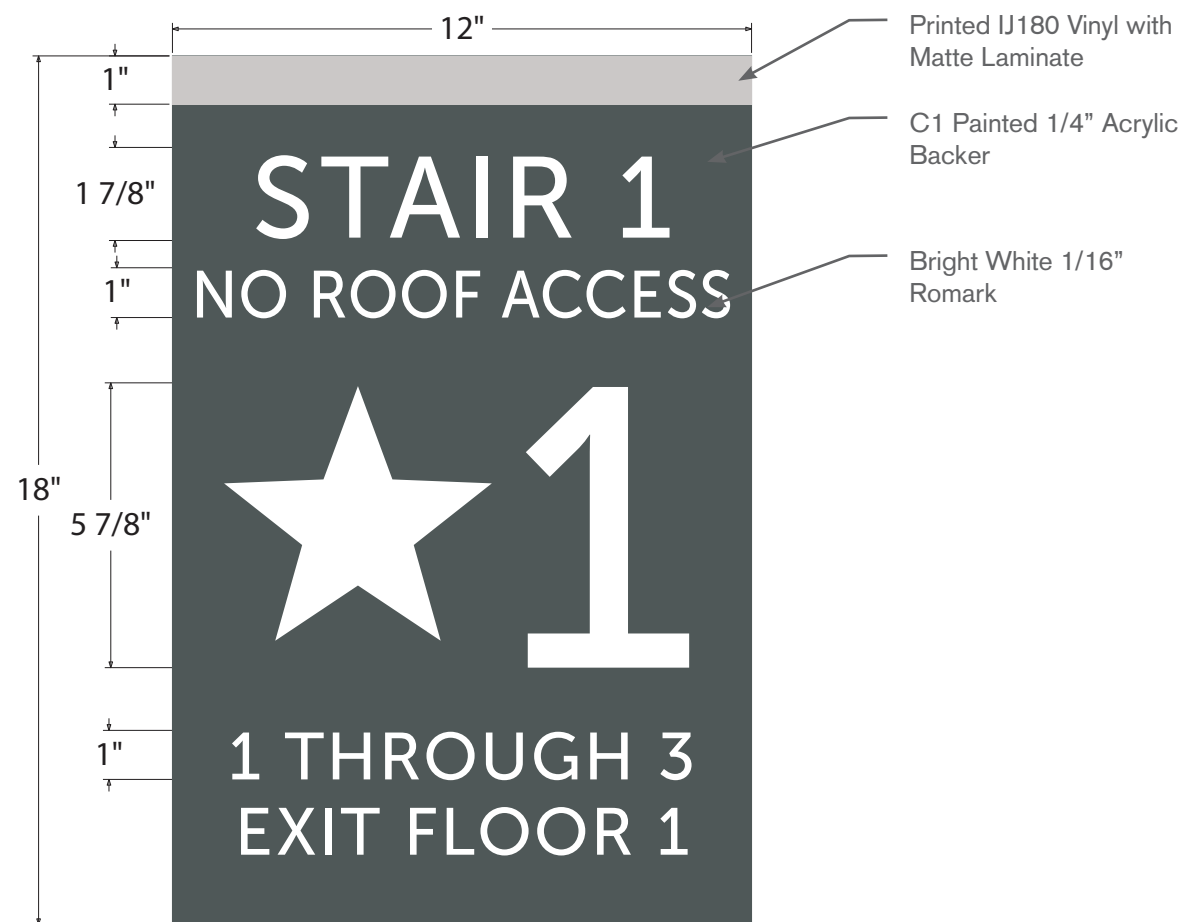

1 FRONT ELEVATION
K.01 Scale: 3" = 1'

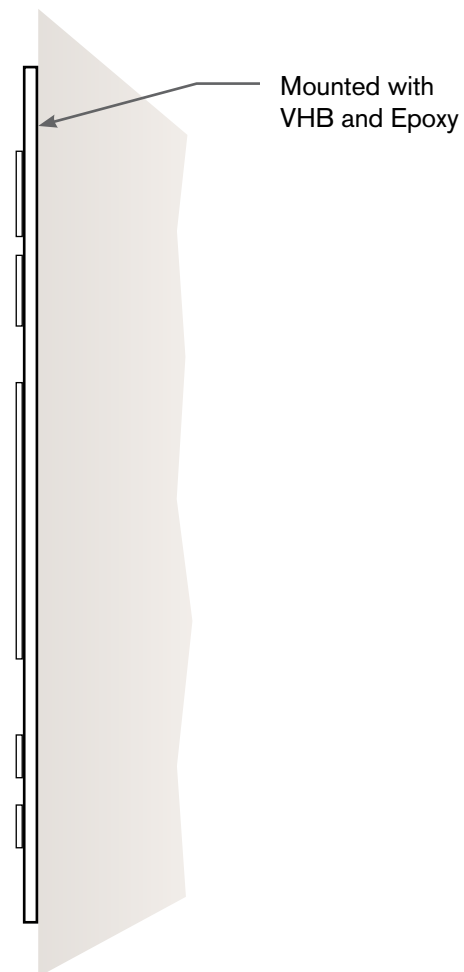

2 TYPICAL MOUNTING
K.01 Scale: 3" = 1'

Notes

6195 Shiloh Road
Suite A
Alpharetta, GA 30005

800-737-4434
yourbenson.com

Benson is a trade name of Benson Media, Inc. All ideas, designs and plans indicated or represented by this drawing are the property of Benson and were created and developed for use in connection with the specified project. They are not to be used, reproduced or copied in whole or in part and shall be returned upon request. None of such ideas, designs or plans shall be used by or disclosed to any persons, firms or corporations for any purpose whatsoever without the written consent of Benson. Copyright © Benson 2015. All rights reserved.

Client

Essex

Project

Signage Master Proof

Job Number

246199

Project Address

Artist **Acct Director**

M.Bando K.Daniel

Colors & Finishes

Colors displayed in this PDF proof are a close representation, but may not be an accurate depiction of final printed/painted/fabricated product. Client to either provide samples or specifications or approve Benson color samples or specifications prior to production.

Modern Industrial

[C1] PMS 445	[C2] PMS 420	[C3] White
[C4] Black	[C5] PMS	

Benson is not responsible for errors or omissions after your proof is approved. Please note that production of this order will not start until all layouts are approved. Proofing is designed to reduce your final cost. Please examine carefully for any errors. Once approved, you are responsible for any and all cost to remake should any errors be found after production begins, no exceptions. You agree to these terms and art approval of the layouts by signing below.

Customer Approval

Proof Approval	AD/CSC	Production
QC Check		Ship: --/-- Install: --/--

Scale	Sheet
As Noted	K.01

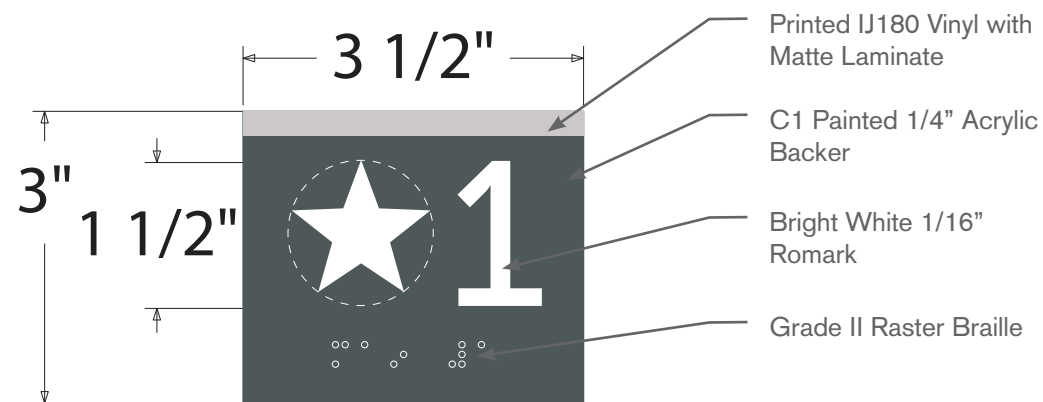

1 FRONT ELEVATION
L.01 Scale: 6" = 1'

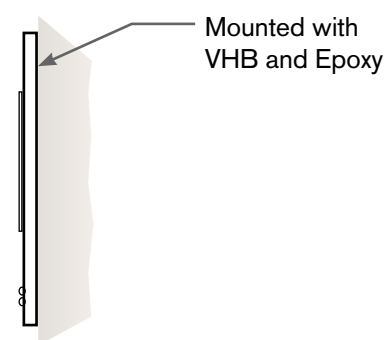

2 TYPICAL MOUNTING
L.01 Scale: 6" = 1'

Notes

6195 Shiloh Road
Suite A
Alpharetta, GA 30005

800-737-4434
yourbenson.com

Benson is a trade name of Benson Media, Inc. All ideas, designs and plans indicated or represented by this drawing are the property of Benson and were created and developed for use in connection with the specified project. They are not to be used, reproduced or copied in whole or in part and shall be returned upon request. None of such ideas, designs or plans shall be used by or disclosed to any persons, firms or corporations for any purpose whatsoever without the written consent of Benson. Copyright © Benson 2015. All rights reserved.

Client	
Essex	
Project	
Signage Master Proof	
Job Number	
246199	
Project Address	
Artist	Acct Director
M.Bando	K.Daniel

Colors & Finishes

Colors displayed in this PDF proof are a close representation, but may not be an accurate depiction of final printed/painted/fabricated product. Client to either provide samples or specifications or approve Benson color samples or specifications prior to production.

Modern Industrial

[C1] PMS 445	[C2] PMS 420	[C3] White
[C4] Black	[C5] PMS	

Benson is not responsible for errors or omissions after your proof is approved. Please note that production of this order will not start until all layouts are approved. Proofing is designed to reduce your final cost. Please examine carefully for any errors. Once approved, you are responsible for any and all cost to remake should any errors be found after production begins, no exceptions. You agree to these terms and art approval of the layouts by signing below.

Customer Approval		
Proof Approval	AD/CSC	Production
QC Check		Ship: --/-- Install: --/--
Scale	Sheet	
As Noted	L.01	

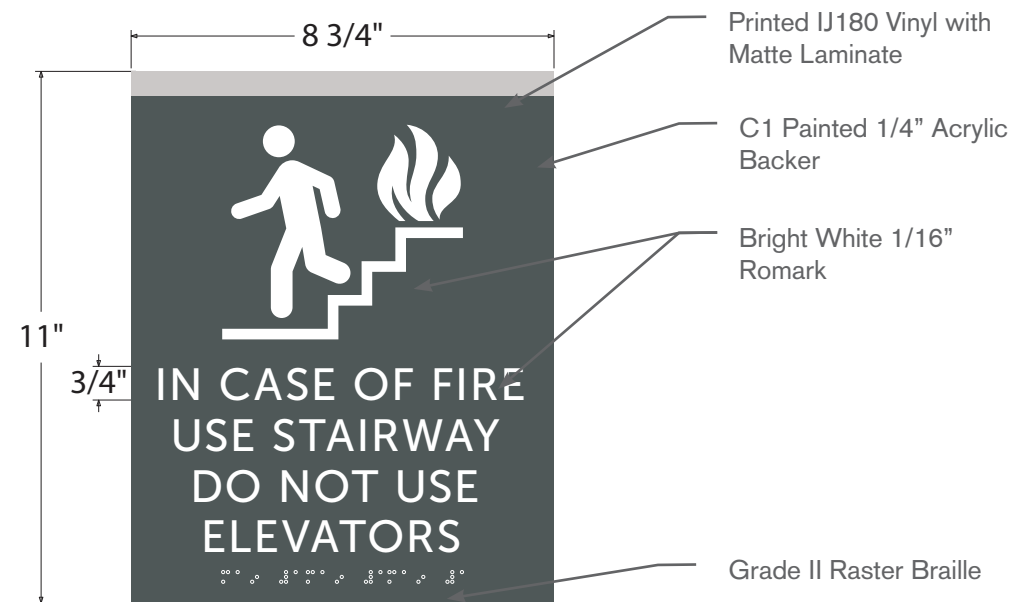

1 FRONT ELEVATION
M.01 Scale: 6" = 1'

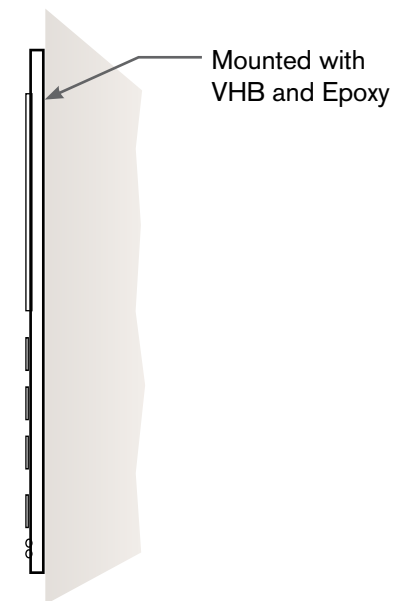

2 TYPICAL MOUNTING
M.01 Scale: 6" = 1'

Notes

6195 Shiloh Road
Suite A
Alpharetta, GA 30005

800-737-4434
yourbenson.com

Benson is a trade name of Benson Media, Inc. All ideas, designs and plans indicated or represented by this drawing are the property of Benson and were created and developed for use in connection with the specified project. They are not to be used, reproduced or copied in whole or in part and shall be returned upon request. None of such ideas, designs or plans shall be used by or disclosed to any persons, firms or corporations for any purpose whatsoever without the written consent of Benson. Copyright © Benson 2015. All rights reserved.

Client	
Essex	
Project	
Signage Master Proof	
Job Number	
246199	
Project Address	
Artist	Acct Director
M.Bando	K.Daniel

Colors & Finishes

Colors displayed in this PDF proof are a close representation, but may not be an accurate depiction of final printed/painted/fabricated product. Client to either provide samples or specifications or approve Benson color samples or specifications prior to production.

Modern Industrial

[C1] PMS 445	[C2] PMS 420	[C3] White
[C4] Black	[C5] PMS	

Benson is not responsible for errors or omissions after your proof is approved. Please note that production of this order will not start until all layouts are approved. Proofing is designed to reduce your final cost. Please examine carefully for any errors. Once approved, you are responsible for any and all cost to remake should any errors be found after production begins, no exceptions. You agree to these terms and art approval of the layouts by signing below.

Customer Approval		
Proof Approval	AD/CSC	Production
QC Check		Ship: --/-- Install: --/--
Scale	Sheet	
As Noted	M.01	

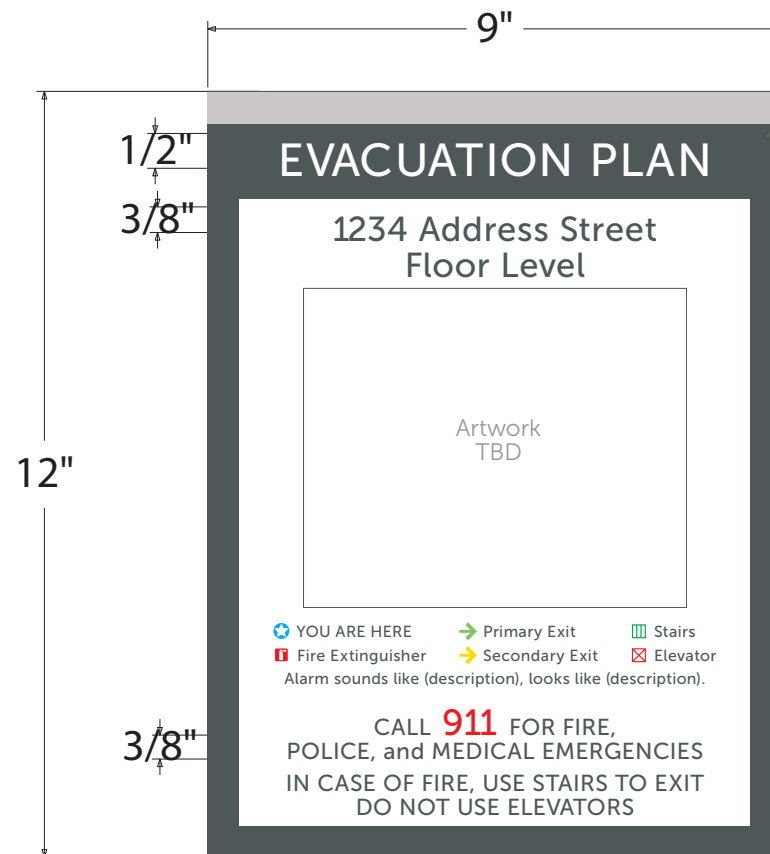

1 FRONT ELEVATION
N.01 Scale: 4" = 1'

Dibond Aluminum Composite Panel With First Surface Applied Digital Print With Protective Matte Laminate

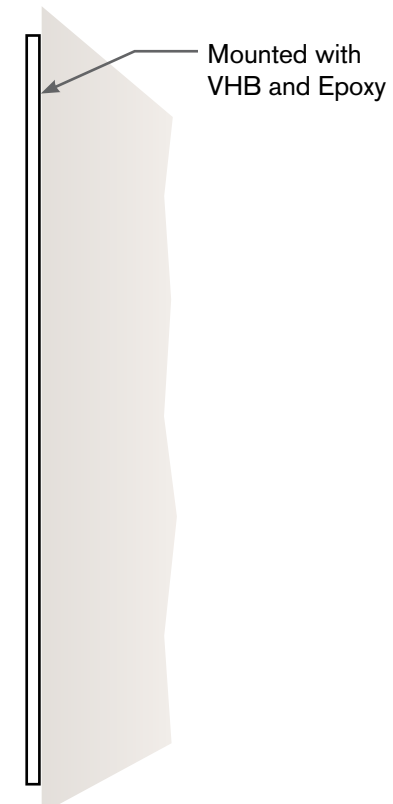

2 TYPICAL MOUNTING
N.01 Scale: 4" = 1'

Notes

6195 Shiloh Road
Suite A
Alpharetta, GA 30005

800-737-4434
yourbenson.com

Benson is a trade name of Benson Media, Inc. All ideas, designs and plans indicated or represented by this drawing are the property of Benson and were created and developed for use in connection with the specified project. They are not to be used, reproduced or copied in whole or in part and shall be returned upon request. None of such ideas, designs or plans shall be used by or disclosed to any persons, firms or corporations for any purpose whatsoever without the written consent of Benson. Copyright © Benson 2015. All rights reserved.

Client	
Essex	
Project	
Signage Master Proof	
Job Number	
246199	
Project Address	
Artist	Acct Director
M.Bando	K.Daniel

Colors & Finishes

Colors displayed in this PDF proof are a close representation, but may not be an accurate depiction of final printed/painted/fabricated product. Client to either provide samples or specifications or approve Benson color samples or specifications prior to production.

Modern Industrial

[C1] PMS 445	[C2] PMS 420	[C3] White
[C4] Black	[C5] PMS	

Benson is not responsible for errors or omissions after your proof is approved. Please note that production of this order will not start until all layouts are approved. Proofing is designed to reduce your final cost. Please examine carefully for any errors. Once approved, you are responsible for any and all cost to remake should any errors be found after production begins, no exceptions. You agree to these terms and art approval of the layouts by signing below.

Customer Approval		
Proof Approval	AD/CSC	Production
QC Check		Ship: --/-- Install: --/--
Scale	Sheet	
As Noted	N.01	

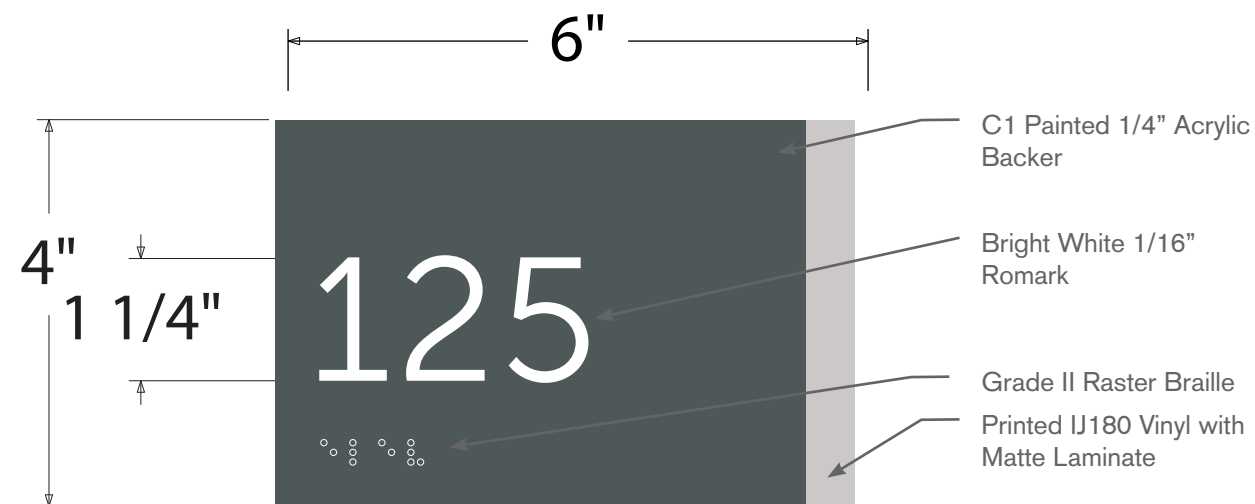

1 FRONT ELEVATION
M.01 Scale: 6" = 1'

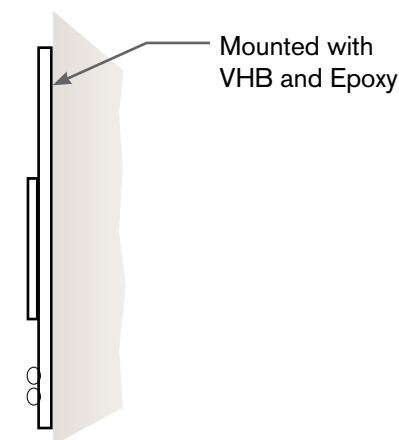

2 TYPICAL MOUNTING
M.01 Scale: 6" = 1'

Notes

6195 Shiloh Road
Suite A
Alpharetta, GA 30005

800-737-4434
yourbenson.com

Benson is a trade name of Benson Media, Inc. All ideas, designs and plans indicated or represented by this drawing are the property of Benson and were created and developed for use in connection with the specified project. They are not to be used, reproduced or copied in whole or in part and shall be returned upon request. None of such ideas, designs or plans shall be used by or disclosed to any persons, firms or corporations for any purpose whatsoever without the written consent of Benson. Copyright © Benson 2015. All rights reserved.

Client	
Essex	
Project	
Signage Master Proof	
Job Number	
246199	
Project Address	
Artist	Acct Director
M.Bando	K.Daniel

Colors & Finishes

Colors displayed in this PDF proof are a close representation, but may not be an accurate depiction of final printed/painted/fabricated product. Client to either provide samples or specifications or approve Benson color samples or specifications prior to production.

Modern Industrial

[C1] PMS 445	[C2] PMS 420	[C3] White
[C4] Black	[C5] PMS	

Benson is not responsible for errors or omissions after your proof is approved. Please note that production of this order will not start until all layouts are approved. Proofing is designed to reduce your final cost. Please examine carefully for any errors. Once approved, you are responsible for any and all cost to remake should any errors be found after production begins, no exceptions. You agree to these terms and art approval of the layouts by signing below.

Customer Approval		
Proof Approval	AD/CSC	Production
QC Check		Ship: --/-- Install: --/--
Scale	Sheet	
As Noted	M.01	



1 FRONT ELEVATION
N.01 Scale: 3" = 1'

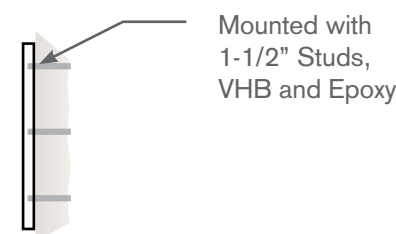

2 SIDE ELEVATION
N.01 Scale: 3" = 1'

Notes

Mounting varies.

6195 Shiloh Road
Suite A
Alpharetta, GA 30005

800-737-4434
yourbenson.com

Benson is a trade name of Benson Media, Inc. All ideas, designs and plans indicated or represented by this drawing are the property of Benson and were created and developed for use in connection with the specified project. They are not to be used, reproduced or copied in whole or in part and shall be returned upon request. None of such ideas, designs or plans shall be used by or disclosed to any persons, firms or corporations for any purpose whatsoever without the written consent of Benson. Copyright © Benson 2015. All rights reserved.

Client	
Essex	
Project	
Signage Master Proof	
Job Number	
246199	
Project Address	
Artist	Acct Director
M.Bando	K.Daniel
Colors & Finishes	
<small>Colors displayed in this PDF proof are a close representation, but may not be an accurate depiction of final printed/painted/fabricated product. Client to either provide samples or specifications or approve Benson color samples or specifications prior to production.</small>	
Modern Industrial	
[C1] PMS 445	[C2] PMS 420
[C3] White	[C4] Black
[C5] PMS	
<small>Benson is not responsible for errors or omissions after your proof is approved. Please note that production of this order will not start until all layouts are approved. Proofing is designed to reduce your final cost. Please examine carefully for any errors. Once approved, you are responsible for any and all cost to remake should any errors be found after production begins, no exceptions. You agree to these terms and art approval of the layouts by signing below.</small>	
Customer Approval	
Proof Approval	AD/CSC Production
QC Check	Ship: --/-- Install: --/--
Scale	Sheet
As Noted	N.01

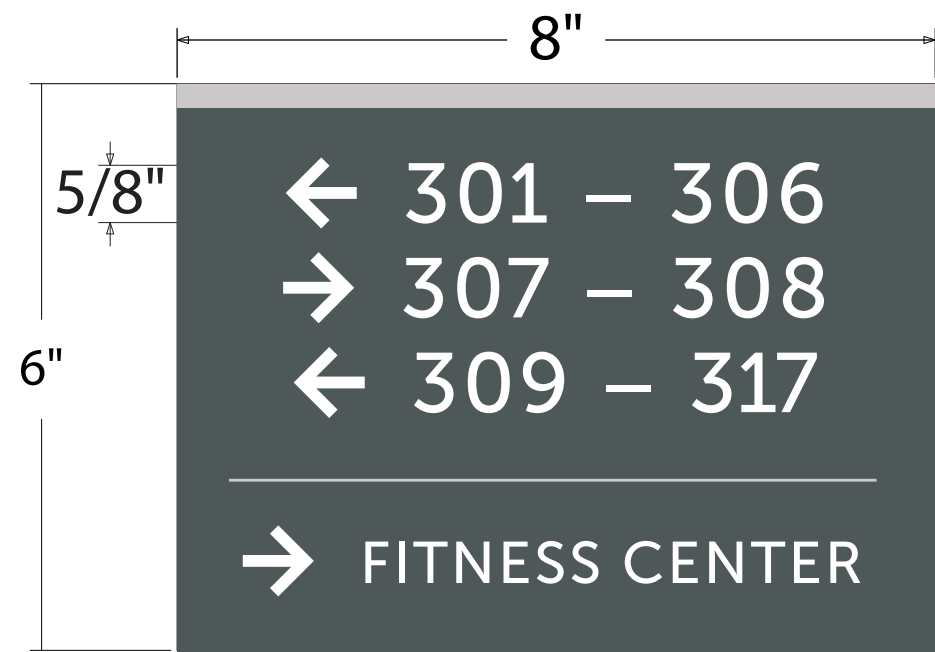
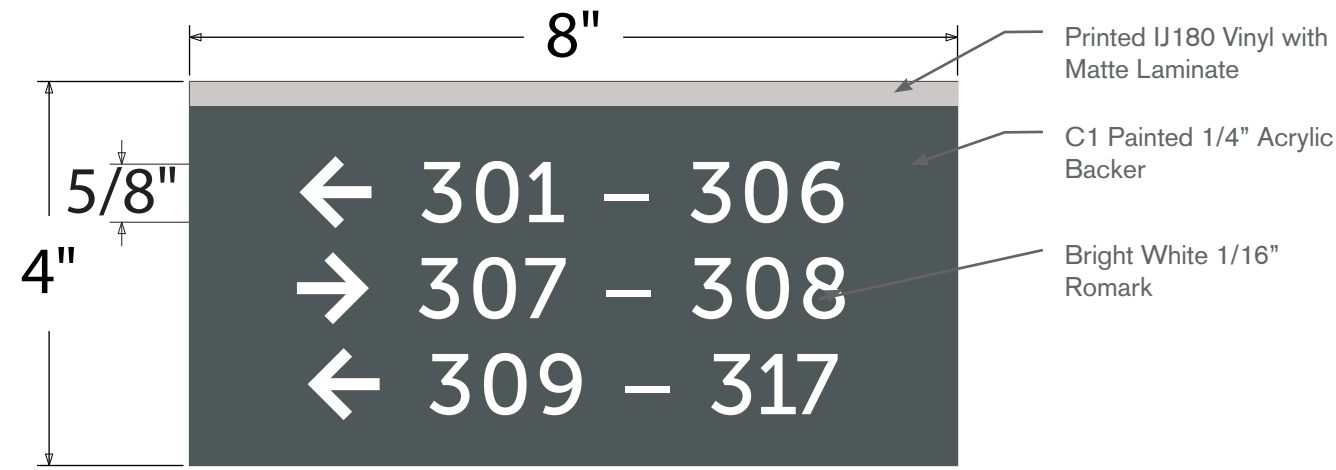

1 FRONT ELEVATION
0.01 Scale: 6" = 1'

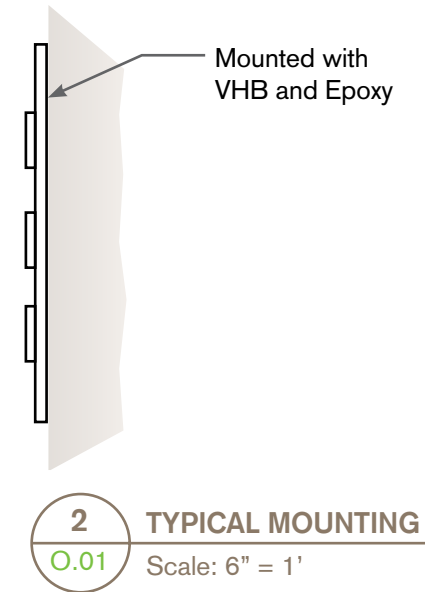

Notes

6195 Shiloh Road Suite A Alpharetta, GA 30005	
800-737-4434 yourbenson.com	
<small>Benson is a trade name of Benson Media, Inc. All ideas, designs and plans indicated or represented by this drawing are the property of Benson and were created and developed for use in connection with the specified project. They are not to be used, reproduced or copied in whole or in part and shall be returned upon request. None of such ideas, designs or plans shall be used by or disclosed to any persons, firms or corporations for any purpose whatsoever without the written consent of Benson. Copyright © Benson 2015. All rights reserved.</small>	
Client	
Essex	
Project	
Signage Master Proof	
Job Number	
246199	
Project Address	
Artist	Acct Director
M.Bando	K.Daniel
Colors & Finishes	
<small>Colors displayed in this PDF proof are a close representation, but may not be an accurate depiction of final printed/painted/fabricated product. Client to either provide samples or specifications or approve Benson color samples or specifications prior to production.</small>	
Modern Industrial	
[C1] PMS 445	[C2] PMS 420
[C3] White	[C4] Black
[C5] PMS	
<small>Benson is not responsible for errors or omissions after your proof is approved. Please note that production of this order will not start until all layouts are approved. Proofing is designed to reduce your final cost. Please examine carefully for any errors. Once approved, you are responsible for any and all cost to remake should any errors be found after production begins, no exceptions. You agree to these terms and art approval of the layouts by signing below.</small>	
Customer Approval	
Proof Approval	AD/CSC Production
QC Check	Ship: --/-- Install: --/--
Scale	Sheet
As Noted	0.01

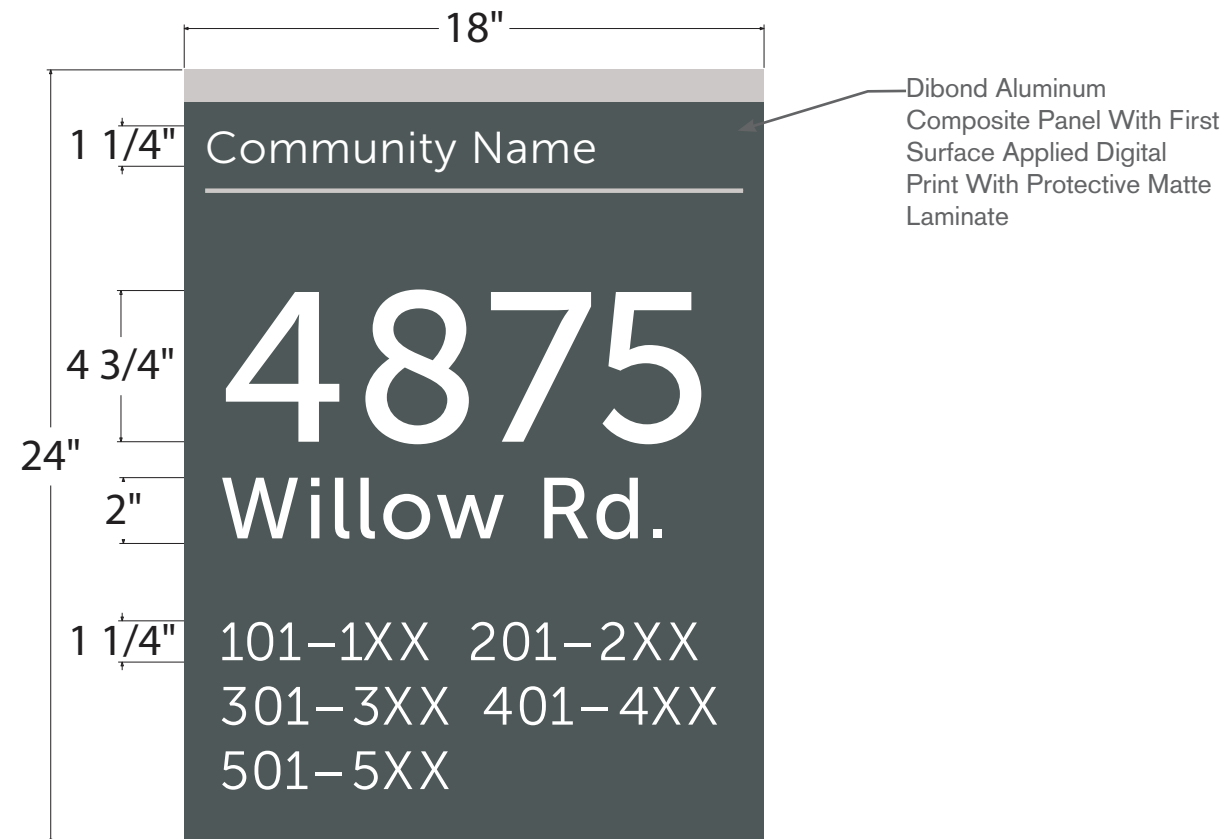

1 FRONT ELEVATION
P.01 Scale: 2" = 1'

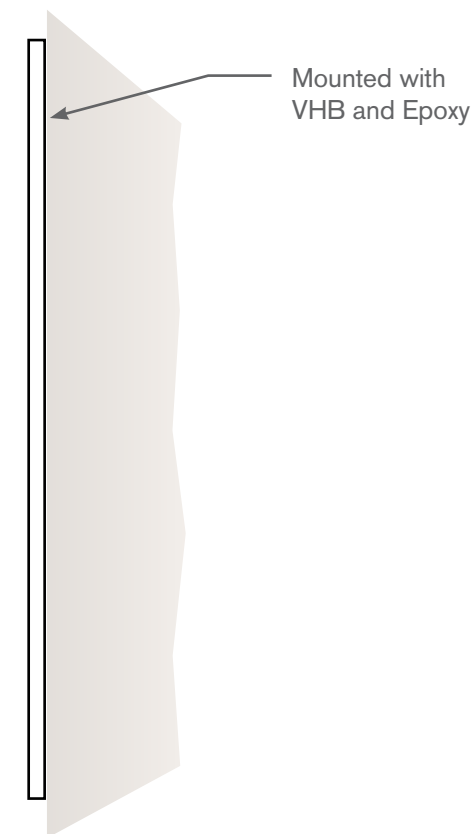

2 SIDE ELEVATION
P.01 Scale: 2" = 1'

Notes

6195 Shiloh Road
Suite A
Alpharetta, GA 30005

800-737-4434
yourbenson.com

Benson is a trade name of Benson Media, Inc. All ideas, designs and plans indicated or represented by this drawing are the property of Benson and were created and developed for use in connection with the specified project. They are not to be used, reproduced or copied in whole or in part and shall be returned upon request. None of such ideas, designs or plans shall be used by or disclosed to any persons, firms or corporations for any purpose whatsoever without the written consent of Benson. Copyright © Benson 2015. All rights reserved.

Client	
Essex	
Project	
Signage Master Proof	
Job Number	
246199	
Project Address	

Artist	Acct Director
M.Bando	K.Daniel

Colors & Finishes

Colors displayed in this PDF proof are a close representation, but may not be an accurate depiction of final printed/painted/fabricated product. Client to either provide samples or specifications or approve Benson color samples or specifications prior to production.

Modern Industrial

[C1] PMS 445	[C2] PMS 420	[C3] White
[C4] Black	[C5] PMS	

Benson is not responsible for errors or omissions after your proof is approved. Please note that production of this order will not start until all layouts are approved. Proofing is designed to reduce your final cost. Please examine carefully for any errors. Once approved, you are responsible for any and all cost to remake should any errors be found after production begins, no exceptions. You agree to these terms and art approval of the layouts by signing below.

Customer Approval		
Proof Approval	AD/CSC	Production
QC Check		Ship: --/-- Install: --/--
Scale	Sheet	
As Noted	P.01	

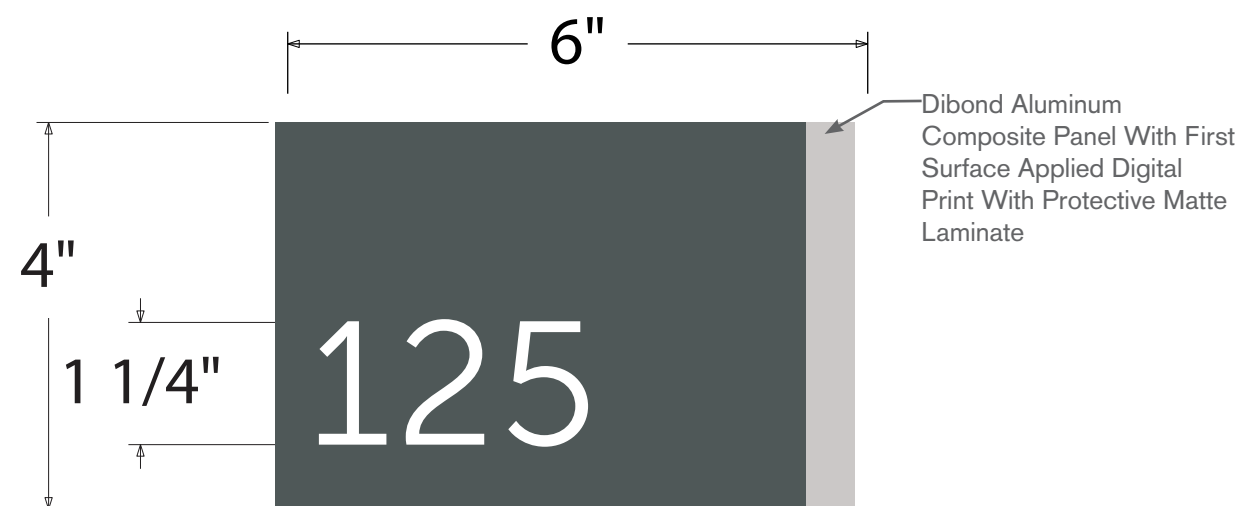

1 FRONT ELEVATION
Q.01 Scale: 6" = 1'

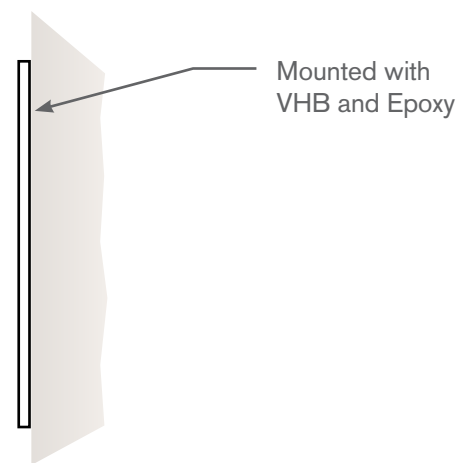

2 SIDE ELEVATION
Q.01 Scale: 6" = 1'

Notes

Mounting varies.

6195 Shiloh Road
Suite A
Alpharetta, GA 30005

800-737-4434
yourbenson.com

Benson is a trade name of Benson Media, Inc. All ideas, designs and plans indicated or represented by this drawing are the property of Benson and were created and developed for use in connection with the specified project. They are not to be used, reproduced or copied in whole or in part and shall be returned upon request. None of such ideas, designs or plans shall be used by or disclosed to any persons, firms or corporations for any purpose whatsoever without the written consent of Benson. Copyright © Benson 2015. All rights reserved.

Client	
Essex	
Project	
Signage Master Proof	
Job Number	
246199	
Project Address	
Artist	Acct Director
M.Bando	K.Daniel

Colors & Finishes

Colors displayed in this PDF proof are a close representation, but may not be an accurate depiction of final printed/painted/fabricated product. Client to either provide samples or specifications or approve Benson color samples or specifications prior to production.

Modern Industrial

[C1]	[C2]	[C3]
PMS 445	PMS 420	White
[C4]	[C5]	
Black	PMS	

Benson is not responsible for errors or omissions after your proof is approved. Please note that production of this order will not start until all layouts are approved. Proofing is designed to reduce your final cost. Please examine carefully for any errors. Once approved, you are responsible for any and all cost to remake should any errors be found after production begins, no exceptions. You agree to these terms and art approval of the layouts by signing below.

Customer Approval		
Proof Approval	AD/CSC	Production
QC Check		Ship: --/-- Install: --/--
Scale	Sheet	
As Noted	Q.01	

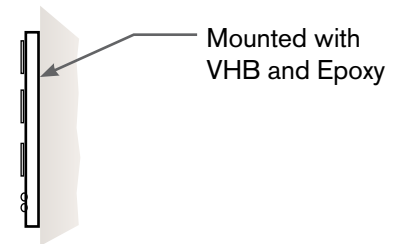
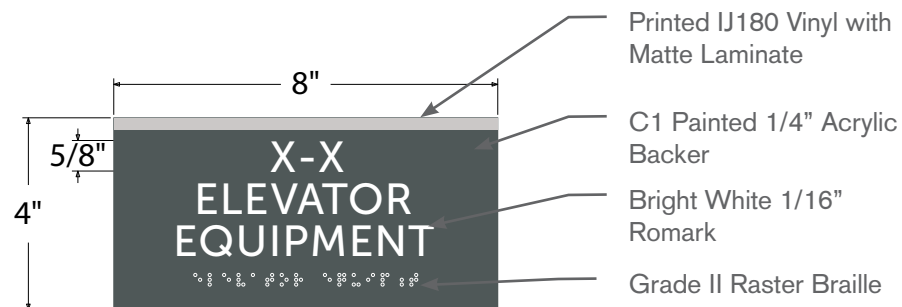

2 TYPICAL MOUNTING
R.01 Scale: 3" = 1'

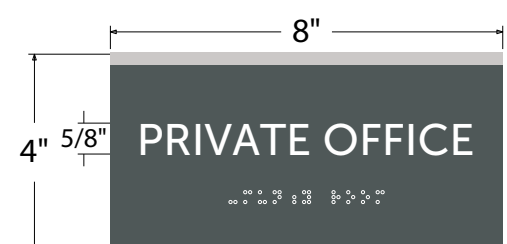
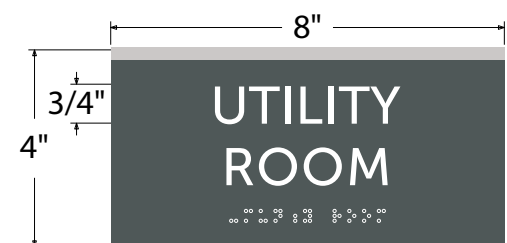

1 FRONT ELEVATION
R.01 Scale: 3" = 1'

Notes

6195 Shiloh Road Suite A Alpharetta, GA 30005	
800-737-4434 yourbenson.com	
<small>Benson is a trade name of Benson Media, Inc. All ideas, designs and plans indicated or represented by this drawing are the property of Benson and were created and developed for use in connection with the specified project. They are not to be used, reproduced or copied in whole or in part and shall be returned upon request. None of such ideas, designs or plans shall be used by or disclosed to any persons, firms or corporations for any purpose whatsoever without the written consent of Benson. Copyright © Benson 2015. All rights reserved.</small>	
Client	
Essex	
Project	
Signage Master Proof	
Job Number	
246199	
Project Address	
Artist	Acct Director
M.Bando	K.Daniel
Colors & Finishes	
<small>Colors displayed in this PDF proof are a close representation, but may not be an accurate depiction of final printed/painted/fabricated product. Client to either provide samples or specifications or approve Benson color samples or specifications prior to production.</small>	
Modern Industrial	
[C1] PMS 445	[C2] PMS 420
[C3] White	[C4] Black
[C5] PMS	
<small>Benson is not responsible for errors or omissions after your proof is approved. Please note that production of this order will not start until all layouts are approved. Proofing is designed to reduce your final cost. Please examine carefully for any errors. Once approved, you are responsible for any and all cost to remake should any errors be found after production begins, no exceptions. You agree to these terms and art approval of the layouts by signing below.</small>	
Customer Approval	
Proof Approval	AD/CSC Production
QC Check	Ship: --/-- Install: --/--
Scale	Sheet
As Noted	R.01

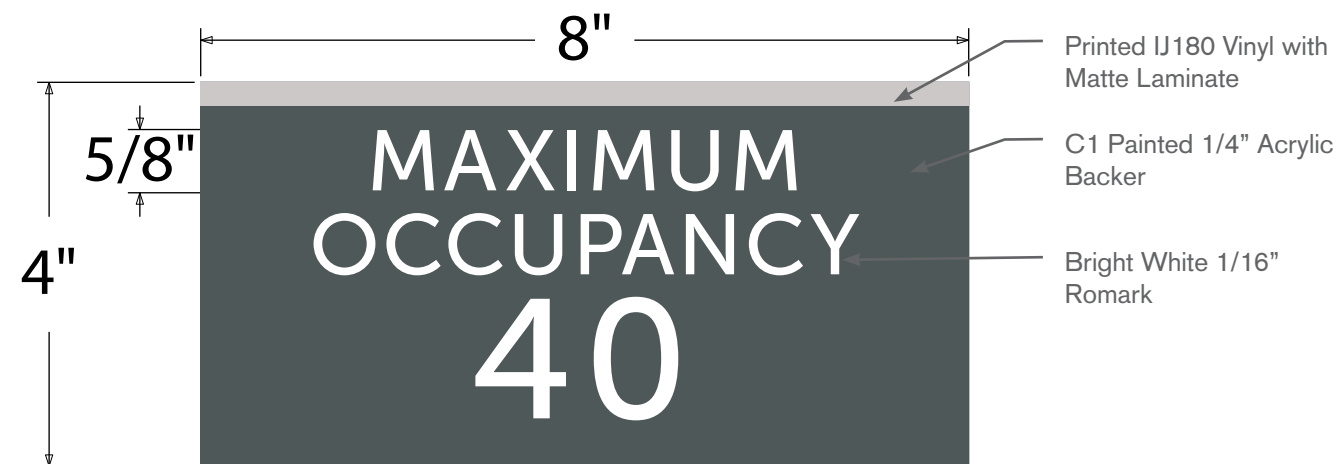

1 FRONT ELEVATION
S.01 Scale: 6" = 1'

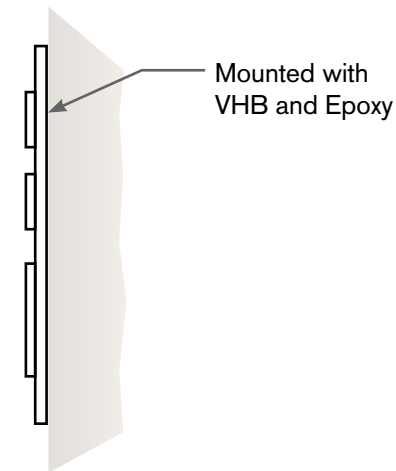

2 TYPICAL MOUNTING
S.01 Scale: 6" = 1'

Notes

6195 Shiloh Road
Suite A
Alpharetta, GA 30005

800-737-4434
yourbenson.com

Benson is a trade name of Benson Media, Inc. All ideas, designs and plans indicated or represented by this drawing are the property of Benson and were created and developed for use in connection with the specified project. They are not to be used, reproduced or copied in whole or in part and shall be returned upon request. None of such ideas, designs or plans shall be used by or disclosed to any persons, firms or corporations for any purpose whatsoever without the written consent of Benson. Copyright © Benson 2015. All rights reserved.

Client

Essex

Project

Signage Master Proof

Job Number

246199

Project Address

Artist **Acct Director**

M.Bando K.Daniel

Colors & Finishes

Colors displayed in this PDF proof are a close representation, but may not be an accurate depiction of final printed/painted/fabricated product. Client to either provide samples or specifications or approve Benson color samples or specifications prior to production.

Modern Industrial

[C1] PMS 445	[C2] PMS 420	[C3] White
[C4] Black	[C5] PMS	

Benson is not responsible for errors or omissions after your proof is approved. Please note that production of this order will not start until all layouts are approved. Proofing is designed to reduce your final cost. Please examine carefully for any errors. Once approved, you are responsible for any and all cost to remake should any errors be found after production begins, no exceptions. You agree to these terms and art approval of the layouts by signing below.

Customer Approval		
Proof Approval	AD/CSC	Production
QC Check		Ship: --/-- Install: --/--
Scale	Sheet	
As Noted	S.01	

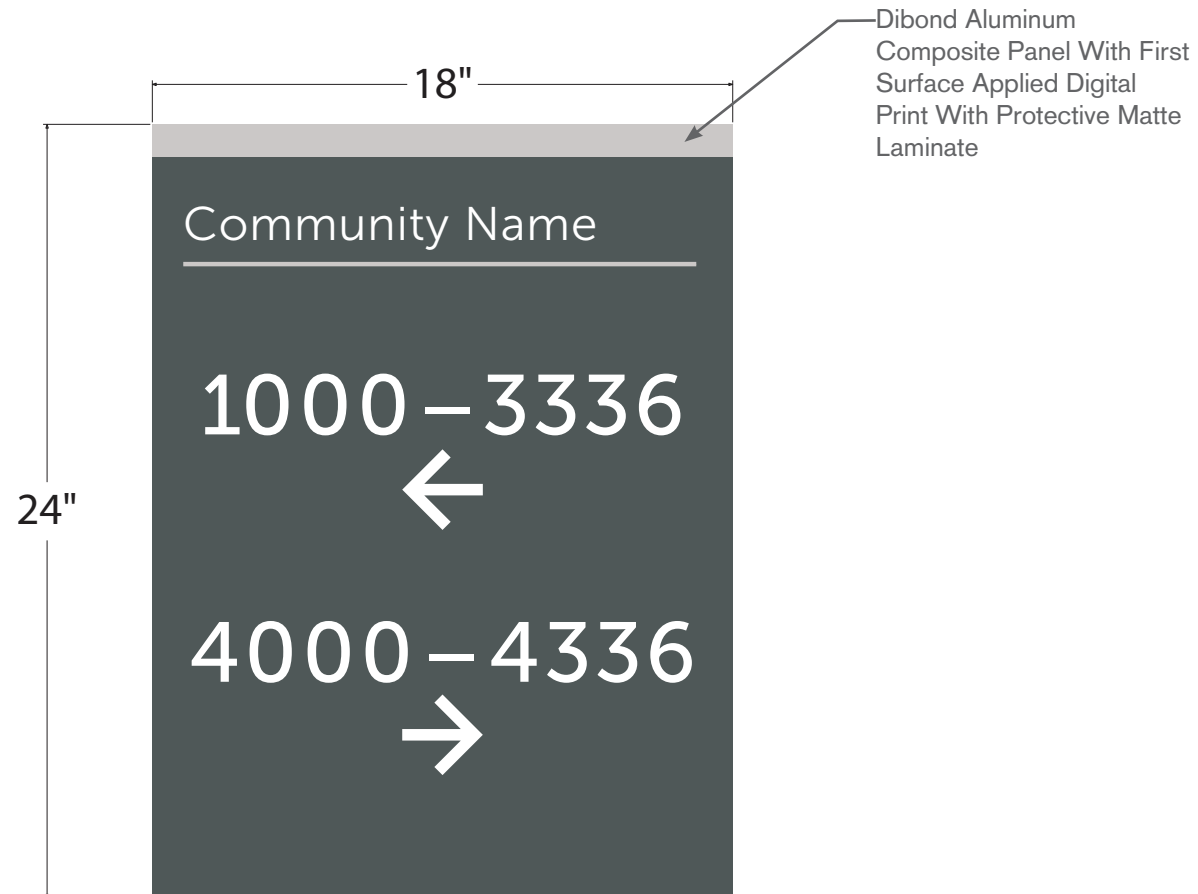

1 FRONT ELEVATION
T.01 Scale: 2" = 1'

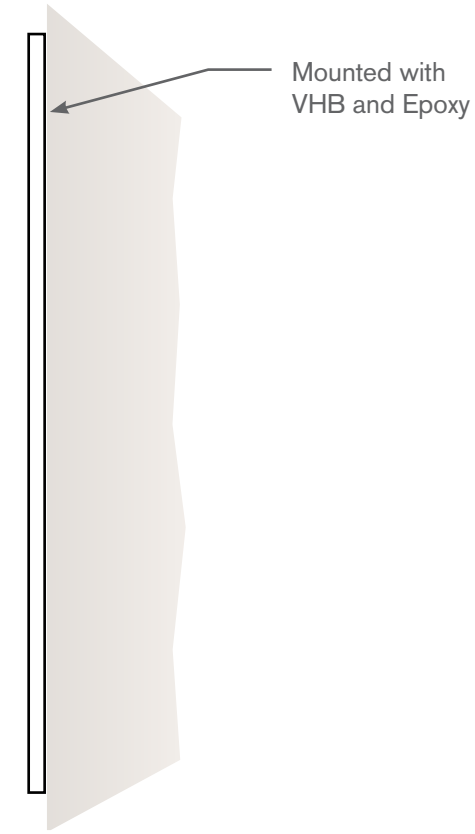

2 SIDE ELEVATION
T.01 Scale: 2" = 1'

Notes

If in parking garage, graphics will be reflective vinyl.

6195 Shiloh Road
Suite A
Alpharetta, GA 30005

800-737-4434
yourbenson.com

Benson is a trade name of Benson Media, Inc. All ideas, designs and plans indicated or represented by this drawing are the property of Benson and were created and developed for use in connection with the specified project. They are not to be used, reproduced or copied in whole or in part and shall be returned upon request. None of such ideas, designs or plans shall be used by or disclosed to any persons, firms or corporations for any purpose whatsoever without the written consent of Benson. Copyright © Benson 2015. All rights reserved.

Client

Essex

Project

Signage Master Proof

Job Number

246199

Project Address

Artist **Acct Director**

M.Bando K.Daniel

Colors & Finishes

Colors displayed in this PDF proof are a close representation, but may not be an accurate depiction of final printed/painted/fabricated product. Client to either provide samples or specifications or approve Benson color samples or specifications prior to production.

Modern Industrial

[C1]	[C2]	[C3]
PMS 445	PMS 420	White
[C4]	[C5]	
Black	PMS	

Benson is not responsible for errors or omissions after your proof is approved. Please note that production of this order will not start until all layouts are approved. Proofing is designed to reduce your final cost. Please examine carefully for any errors. Once approved, you are responsible for any and all cost to remake should any errors be found after production begins, no exceptions. You agree to these terms and art approval of the layouts by signing below.

Customer Approval

Proof Approval	AD/CSC	Production
QC Check		Ship: --/-- Install: --/--

Scale	Sheet
As Noted	T.01

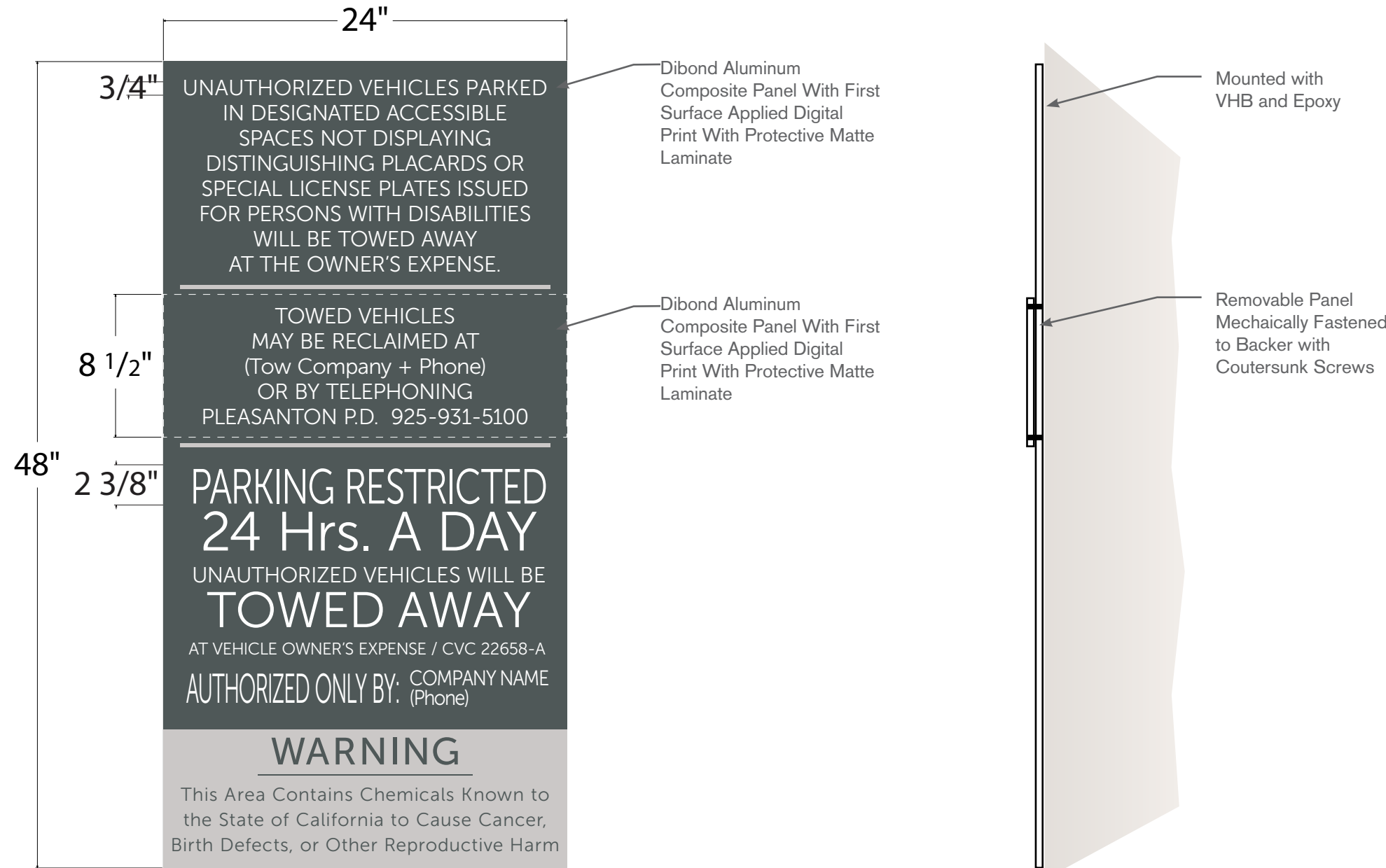

1 FRONT ELEVATION
U.01 Scale: 2" = 1'

2 SIDE ELEVATION
U.01 Scale: 2" = 1'

Notes

Mounting varies.

6195 Shiloh Road Suite A Alpharetta, GA 30005	
800-737-4434 yourbenson.com	
<small>Benson is a trade name of Benson Media, Inc. All ideas, designs and plans indicated or represented by this drawing are the property of Benson and were created and developed for use in connection with the specified project. They are not to be used, reproduced or copied in whole or in part and shall be returned upon request. None of such ideas, designs or plans shall be used by or disclosed to any persons, firms or corporations for any purpose whatsoever without the written consent of Benson. Copyright © Benson 2015. All rights reserved.</small>	
Client	
Essex	
Project	
Signage Master Proof	
Job Number	
246199	
Project Address	
Artist	Acct Director
M.Bando	K.Daniel
Colors & Finishes	
<small>Colors displayed in this PDF proof are a close representation, but may not be an accurate depiction of final printed/painted/fabricated product. Client to either provide samples or specifications or approve Benson color samples or specifications prior to production.</small>	
Modern Industrial	
[C1] PMS 445	[C2] PMS 420
[C3] White	[C4] Black
[C5] PMS	
<small>Benson is not responsible for errors or omissions after your proof is approved. Please note that production of this order will not start until all layouts are approved. Proofing is designed to reduce your final cost. Please examine carefully for any errors. Once approved, you are responsible for any and all cost to remake should any errors be found after production begins, no exceptions. You agree to these terms and art approval of the layouts by signing below.</small>	
Customer Approval	
Proof Approval	AD/CSC Production
QC Check	Ship: --/-- Install: --/--
Scale	Sheet
As Noted	U.01

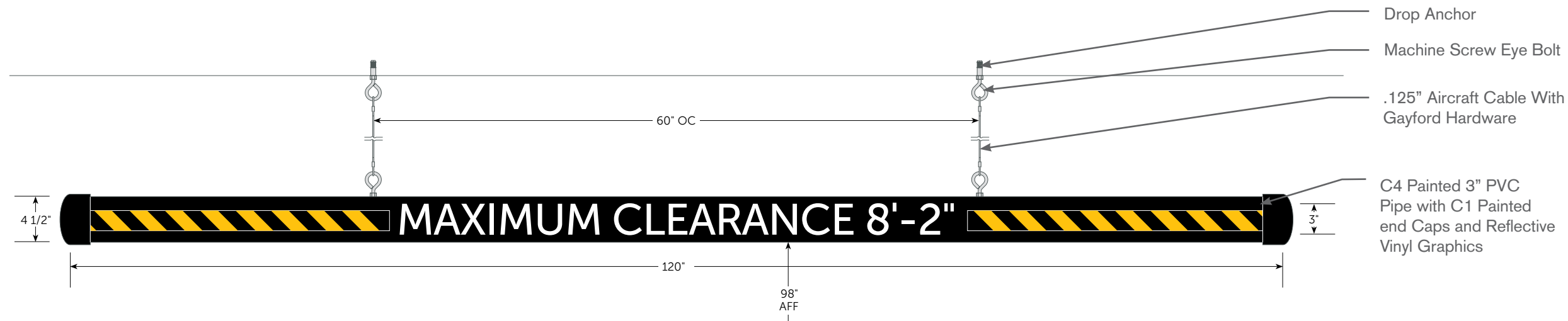

1 FRONT ELEVATION
V.01 Scale: 1" = 1'

Notes

Mounting may vary.

6195 Shiloh Road
Suite A
Alpharetta, GA 30005

800-737-4434
yourbenson.com

Benson is a trade name of Benson Media, Inc. All ideas, designs and plans indicated or represented by this drawing are the property of Benson and were created and developed for use in connection with the specified project. They are not to be used, reproduced or copied in whole or in part and shall be returned upon request. None of such ideas, designs or plans shall be used by or disclosed to any persons, firms or corporations for any purpose whatsoever without the written consent of Benson. Copyright © Benson 2015. All rights reserved.

Client	
Essex	
Project	
Signage Master Proof	
Job Number	
246199	
Project Address	

Artist	Acct Director
M.Bando	K.Daniel

Colors & Finishes

Colors displayed in this PDF proof are a close representation, but may not be an accurate depiction of final printed/painted/fabricated product. Client to either provide samples or specifications or approve Benson color samples or specifications prior to production.

Modern Industrial

[C1] PMS 445	[C2] PMS 420	[C3] White
[C4] Black	[C5] PMS	

Benson is not responsible for errors or omissions after your proof is approved. Please note that production of this order will not start until all layouts are approved. Proofing is designed to reduce your final cost. Please examine carefully for any errors. Once approved, you are responsible for any and all cost to remake should any errors be found after production begins, no exceptions. You agree to these terms and art approval of the layouts by signing below.

Customer Approval		
Proof Approval	AD/CSC	Production
QC Check		Ship: --/-- Install: --/--
Scale	Sheet	
As Noted	V.01	

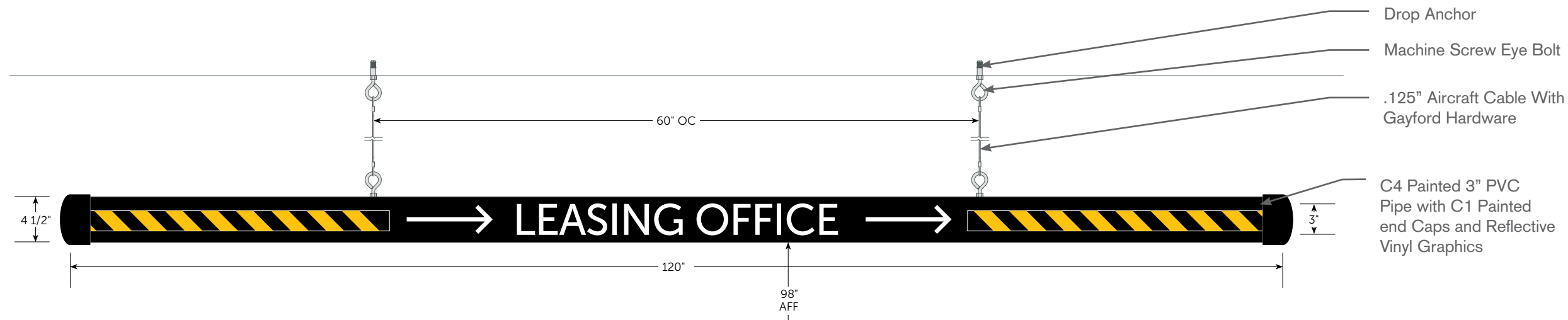

1 FRONT ELEVATION
W.01 Scale: 1" = 1'

Notes

Mounting may vary.

6195 Shiloh Road
Suite A
Alpharetta, GA 30005

800-737-4434
yourbenson.com

Benson is a trade name of Benson Media, Inc. All ideas, designs and plans indicated or represented by this drawing are the property of Benson and were created and developed for use in connection with the specified project. They are not to be used, reproduced or copied in whole or in part and shall be returned upon request. None of such ideas, designs or plans shall be used by or disclosed to any persons, firms or corporations for any purpose whatsoever without the written consent of Benson. Copyright © Benson 2015. All rights reserved.

Client

Essex

Project

Signage Master Proof

Job Number

246199

Project Address

Artist **Acct Director**

M.Bando K.Daniel

Colors & Finishes

Colors displayed in this PDF proof are a close representation, but may not be an accurate depiction of final printed/painted/fabricated product. Client to either provide samples or specifications or approve Benson color samples or specifications prior to production.

Modern Industrial

[C1] PMS 445	[C2] PMS 420	[C3] White
[C4] Black	[C5] PMS	

Benson is not responsible for errors or omissions after your proof is approved. Please note that production of this order will not start until all layouts are approved. Proofing is designed to reduce your final cost. Please examine carefully for any errors. Once approved, you are responsible for any and all cost to remake should any errors be found after production begins, no exceptions. You agree to these terms and art approval of the layouts by signing below.

Customer Approval		
Proof Approval	AD/CSC	Production
QC Check		Ship: --/-- Install: --/--
Scale	Sheet	
As Noted	W.01	

Community Name

FITNESS CENTER GUIDELINES

- This facility is to be used at your own risk.
- Appropriate workout clothing must include a shirt and shoes.
- If coming from the pool, please dry off before entering.
- Beverages are only permitted in spill-proof containers.
- No food allowed.
- Please wipe down equipment after each use.
- Report any broken or damaged equipment to management immediately.
- Adult supervision is required for anyone under 16 years of age.
- Limit usage time to 30 minutes when others are waiting.
- Any violation of the above rules may jeopardize your usage.
- This facility is for the sole use of residents.

Hours: 00 am to 00 pm

Community Name

BUSINESS CENTER GUIDELINES

- For the use of residents only.
- Adult supervision is required for anyone under 16 years of age.
- No pets permitted.
- No smoking, eating or drinking.
- Resident is responsible for any damages.
- Please report all technical difficulties to management.
- Proper attire including shoes and shirt must be worn in the Business Center. No wet bathing suits.

COMPUTER USE

- All files must be saved on resident's own devices.
- Any files saved to the hard drive will be deleted.

FAX USE

- Programmed for local faxes only.
- A calling card must be used for long distance.

COPIER USE

- Please do not attempt to change the toner.
- Contact management office for assistance.

Hours: 00 am to 00 pm

1 FRONT ELEVATION
X.01 Scale: 2" = 1'

Community Name

CLUB ROOM GUIDELINES

- This facility is restricted to residents and their guests. Guests may be allowed if accompanied by the resident. Photo ID may be required.
- Adult supervision is required for anyone under 14 years of age.
- Management reserves the right to deny use of this facility to anyone at any time.
- No alcoholic beverages, obscene language, or smoking is allowed. Please be considerate of others.
- Please report to Management the misuse, damage, or malfunctioning of equipment.
- Please remove all personal items when leaving.
- This area is not supervised. If unfamiliar with the equipment, please refrain from using until you receive proper instruction.
- No pets allowed. (This provision does not apply to service animals used by disabled persons.)

Hours: 00 am to 00 pm

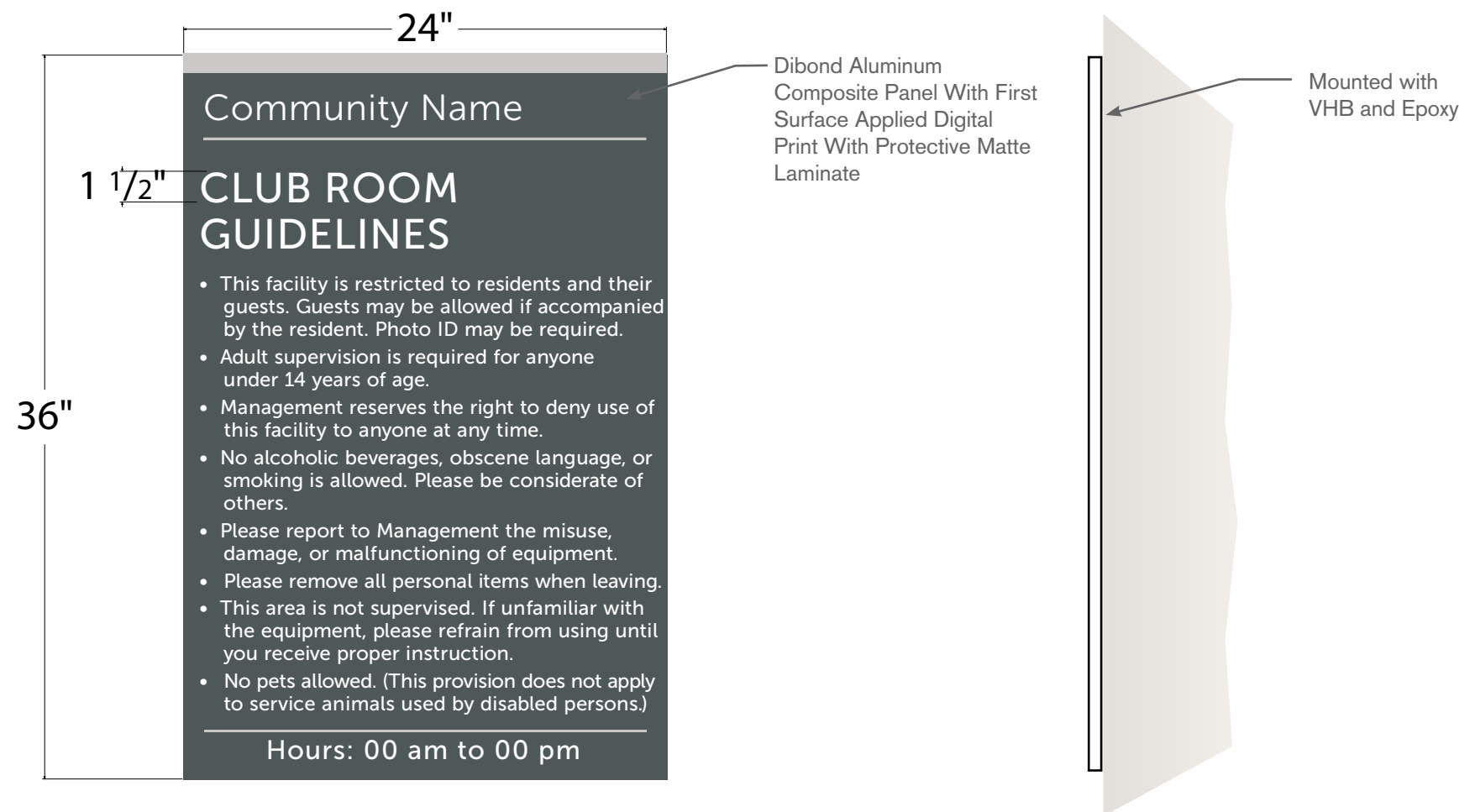

2 SIDE ELEVATION
X.01 Scale: 2" = 1'

Notes

6195 Shiloh Road Suite A Alpharetta, GA 30005	
800-737-4434 yourbenson.com	
<small>Benson is a trade name of Benson Media, Inc. All ideas, designs and plans indicated or represented by this drawing are the property of Benson and were created and developed for use in connection with the specified project. They are not to be used, reproduced or copied in whole or in part and shall be returned upon request. None of such ideas, designs or plans shall be used by or disclosed to any persons, firms or corporations for any purpose whatsoever without the written consent of Benson. Copyright © Benson 2015. All rights reserved.</small>	
Client	
Essex	
Project	
Signage Master Proof	
Job Number	
246199	
Project Address	
Artist	Acct Director
M.Bando	K.Daniel
Colors & Finishes	
<small>Colors displayed in this PDF proof are a close representation, but may not be an accurate depiction of final printed/painted/fabricated product. Client to either provide samples or specifications or approve Benson color samples or specifications prior to production.</small>	
Modern Industrial	
[C1] PMS 445	[C2] PMS 420
[C3] White	[C4] Black
[C5] PMS	
<small>Benson is not responsible for errors or omissions after your proof is approved. Please note that production of this order will not start until all layouts are approved. Proofing is designed to reduce your final cost. Please examine carefully for any errors. Once approved, you are responsible for any and all cost to remake should any errors be found after production begins, no exceptions. You agree to these terms and art approval of the layouts by signing below.</small>	
Customer Approval	
Proof Approval	AD/CSC Production
QC Check	Ship: --/-- Install: --/--
Scale	Sheet
As Noted	X.01

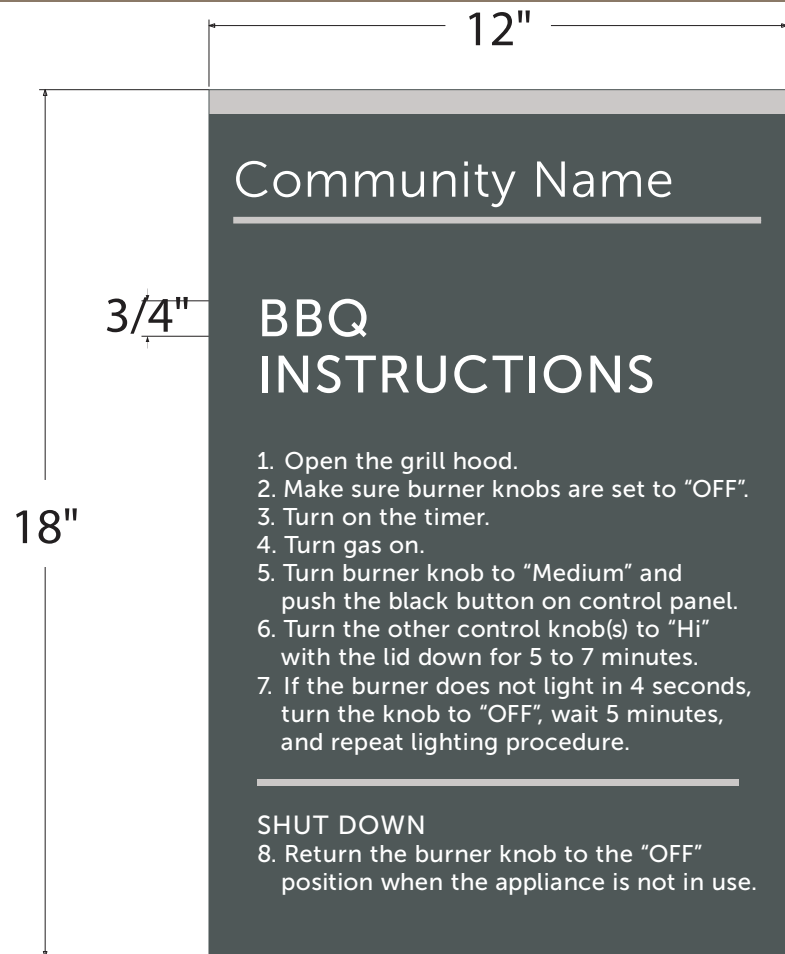

1 FRONT ELEVATION
Y.01 Scale: 2" = 1'



Dibond Aluminum Composite Panel With First Surface Applied Digital Print With Protective Matte Laminate



2 SIDE ELEVATION
Y.01 Scale: 2" = 1'



Notes

6195 Shiloh Road Suite A Alpharetta, GA 30005	
800-737-4434 yourbenson.com	
<small>Benson is a trade name of Benson Media, Inc. All ideas, designs and plans indicated or represented by this drawing are the property of Benson and were created and developed for use in connection with the specified project. They are not to be used, reproduced or copied in whole or in part and shall be returned upon request. None of such ideas, designs or plans shall be used by or disclosed to any persons, firms or corporations for any purpose whatsoever without the written consent of Benson. Copyright © Benson 2015. All rights reserved.</small>	
Client	
Essex	
Project	
Signage Master Proof	
Job Number	
246199	
Project Address	
Artist	Acct Director
M.Bando	K.Daniel
Colors & Finishes	
<small>Colors displayed in this PDF proof are a close representation, but may not be an accurate depiction of final printed/painted/fabricated product. Client to either provide samples or specifications or approve Benson color samples or specifications prior to production.</small>	
Modern Industrial	
[C1] PMS 445	[C2] PMS 420
[C3] White	[C4] Black
[C5] PMS	
<small>Benson is not responsible for errors or omissions after your proof is approved. Please note that production of this order will not start until all layouts are approved. Proofing is designed to reduce your final cost. Please examine carefully for any errors. Once approved, you are responsible for any and all cost to remake should any errors be found after production begins, no exceptions. You agree to these terms and art approval of the layouts by signing below.</small>	
Customer Approval	
Proof Approval	AD/CSC
QC Check	Production
Ship: --/--	Install: --/--
Scale	Sheet
As Noted	Y.01

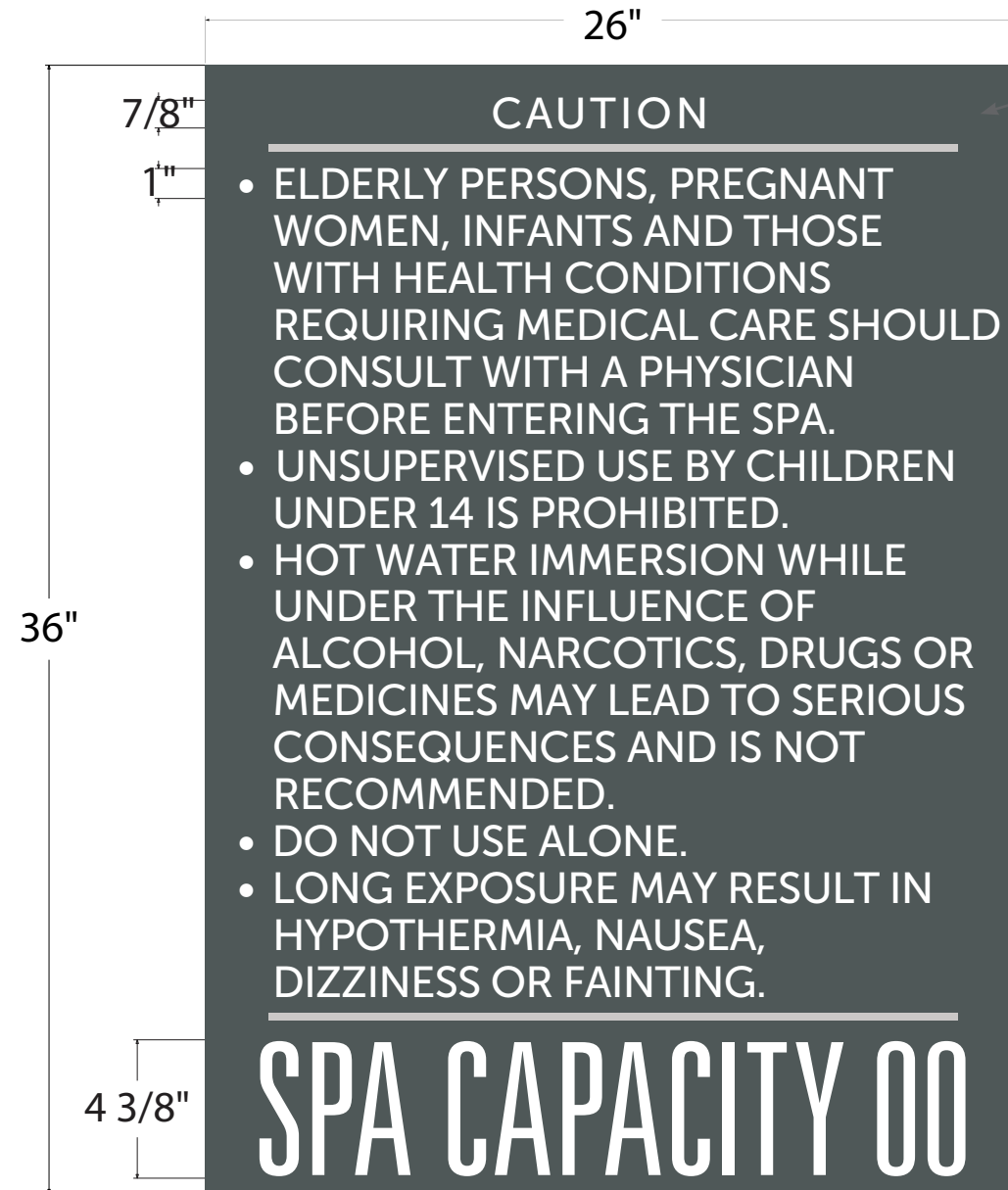

Dibond Aluminum Composite Panel With First Surface Applied Digital Print With Protective Matte Laminate

Mounted with VHB and Epoxy

1 FRONT ELEVATION
Z.01 Scale: 2" = 1'

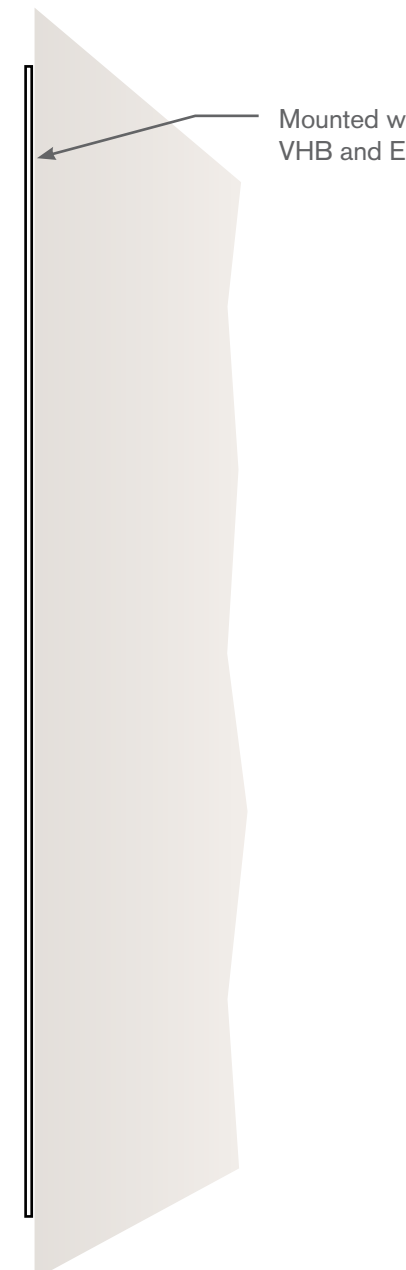

2 SIDE ELEVATION
Z.01 Scale: 2" = 1'

Notes

Rules changed to match state and local requirements.
Mounting may vary.

6195 Shiloh Road Suite A Alpharetta, GA 30005	
800-737-4434 yourbenson.com	
<small>Benson is a trade name of Benson Media, Inc. All ideas, designs and plans indicated or represented by this drawing are the property of Benson and were created and developed for use in connection with the specified project. They are not to be used, reproduced or copied in whole or in part and shall be returned upon request. None of such ideas, designs or plans shall be used by or disclosed to any persons, firms or corporations for any purpose whatsoever without the written consent of Benson. Copyright © Benson 2015. All rights reserved.</small>	
Client	
Essex	
Project	
Signage Master Proof	
Job Number	
246199	
Project Address	
Artist	Acct Director
M.Bando	K.Daniel
Colors & Finishes	
<small>Colors displayed in this PDF proof are a close representation, but may not be an accurate depiction of final printed/painted/fabricated product. Client to either provide samples or specifications or approve Benson color samples or specifications prior to production.</small>	
Modern Industrial	
[C1] PMS 445	[C2] PMS 420
[C3] White	[C4] Black
[C5] PMS	
<small>Benson is not responsible for errors or omissions after your proof is approved. Please note that production of this order will not start until all layouts are approved. Proofing is designed to reduce your final cost. Please examine carefully for any errors. Once approved, you are responsible for any and all cost to remake should any errors be found after production begins, no exceptions. You agree to these terms and art approval of the layouts by signing below.</small>	
Customer Approval	
Proof Approval	AD/CSC Production
QC Check	Ship: --/-- Install: --/--
Scale	Sheet
As Noted	Z.01



Dibond Aluminum Composite Panel With First Surface Applied Digital Print With Protective Matte Laminate

Mounted with VHB and Epoxy

1 FRONT ELEVATION
AA.01 Scale: 2" = 1'

2 SIDE ELEVATION
AA.01 Scale: 2" = 1'

Notes

Rules changed to match state and local requirements.
Mounting may vary.

6195 Shiloh Road Suite A Alpharetta, GA 30005	
800-737-4434 yourbenson.com	
<small>Benson is a trade name of Benson Media, Inc. All ideas, designs and plans indicated or represented by this drawing are the property of Benson and were created and developed for use in connection with the specified project. They are not to be used, reproduced or copied in whole or in part and shall be returned upon request. None of such ideas, designs or plans shall be used by or disclosed to any persons, firms or corporations for any purpose whatsoever without the written consent of Benson. Copyright © Benson 2015. All rights reserved.</small>	
Client	
Essex	
Project	
Signage Master Proof	
Job Number	
246199	
Project Address	
Artist	Acct Director
M.Bando	K.Daniel
Colors & Finishes	
<small>Colors displayed in this PDF proof are a close representation, but may not be an accurate depiction of final printed/painted/fabricated product. Client to either provide samples or specifications or approve Benson color samples or specifications prior to production.</small>	
Modern Industrial	
[C1] PMS 445	[C2] PMS 420
[C3] White	[C4] Black
[C5] PMS	
<small>Benson is not responsible for errors or omissions after your proof is approved. Please note that production of this order will not start until all layouts are approved. Proofing is designed to reduce your final cost. Please examine carefully for any errors. Once approved, you are responsible for any and all cost to remake should any errors be found after production begins, no exceptions. You agree to these terms and art approval of the layouts by signing below.</small>	
Customer Approval	
Proof Approval	AD/CSC Production
QC Check	Ship: --/-- Install: --/--
Scale	Sheet
As Noted	AA.01

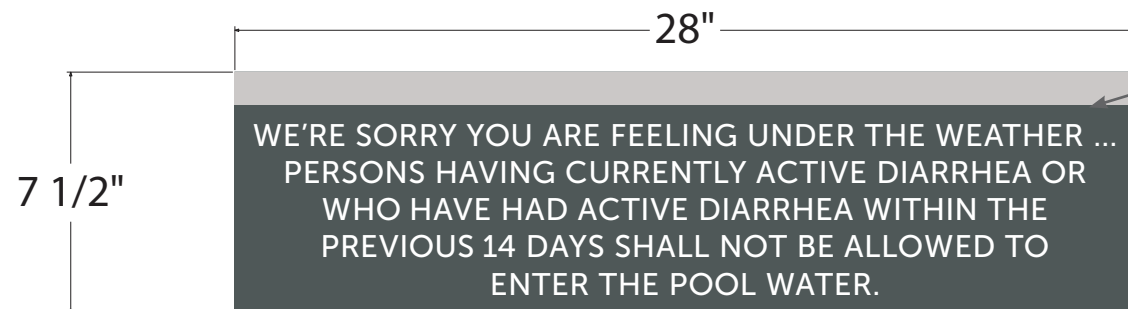

1 FRONT ELEVATION
BB.01 Scale: 2" = 1'

Dibond Aluminum Composite Panel With First Surface Applied Digital Print With Protective Matte Laminate

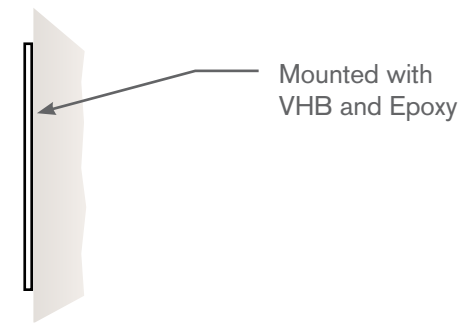

2 SIDE ELEVATION
BB.01 Scale: 2" = 1'

Notes

6195 Shiloh Road
Suite A
Alpharetta, GA 30005

800-737-4434
yourbenson.com

Benson is a trade name of Benson Media, Inc. All ideas, designs and plans indicated or represented by this drawing are the property of Benson and were created and developed for use in connection with the specified project. They are not to be used, reproduced or copied in whole or in part and shall be returned upon request. None of such ideas, designs or plans shall be used by or disclosed to any persons, firms or corporations for any purpose whatsoever without the written consent of Benson. Copyright © Benson 2015. All rights reserved.

Client	
Essex	
Project	
Signage Master Proof	
Job Number	
246199	
Project Address	
Artist	Acct Director
M.Bando	K.Daniel

Colors & Finishes

Colors displayed in this PDF proof are a close representation, but may not be an accurate depiction of final printed/painted/fabricated product. Client to either provide samples or specifications or approve Benson color samples or specifications prior to production.

Modern Industrial

[C1] PMS 445	[C2] PMS 420	[C3] White
[C4] Black	[C5] PMS	

Benson is not responsible for errors or omissions after your proof is approved. Please note that production of this order will not start until all layouts are approved. Proofing is designed to reduce your final cost. Please examine carefully for any errors. Once approved, you are responsible for any and all cost to remake should any errors be found after production begins, no exceptions. You agree to these terms and art approval of the layouts by signing below.

Customer Approval		
Proof Approval	AD/CSC	Production
QC Check		Ship: --/-- Install: --/--
Scale	Sheet	
As Noted	BB.01	

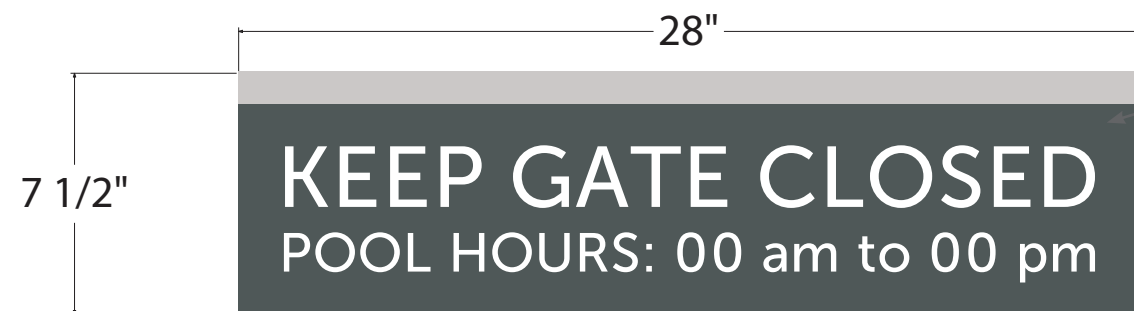

Dibond Aluminum Composite Panel With First Surface Applied Digital Print With Protective Matte Laminate

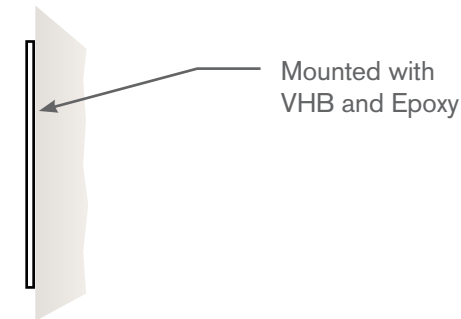

Mounted with VHB and Epoxy

1 FRONT ELEVATION
CC.01 Scale: 2" = 1'

2 SIDE ELEVATION
CC.01 Scale: 2" = 1'

Notes

6195 Shiloh Road
Suite A
Alpharetta, GA 30005

800-737-4434
yourbenson.com

Benson is a trade name of Benson Media, Inc. All ideas, designs and plans indicated or represented by this drawing are the property of Benson and were created and developed for use in connection with the specified project. They are not to be used, reproduced or copied in whole or in part and shall be returned upon request. None of such ideas, designs or plans shall be used by or disclosed to any persons, firms or corporations for any purpose whatsoever without the written consent of Benson. Copyright © Benson 2015. All rights reserved.

Client	
Essex	
Project	
Signage Master Proof	
Job Number	
246199	
Project Address	
Artist	Acct Director
M.Bando	K.Daniel
Colors & Finishes	
<small>Colors displayed in this PDF proof are a close representation, but may not be an accurate depiction of final printed/painted/fabricated product. Client to either provide samples or specifications or approve Benson color samples or specifications prior to production.</small>	
Modern Industrial	
[C1] PMS 445	[C2] PMS 420
[C3] White	[C4] Black
[C5] PMS	
<small>Benson is not responsible for errors or omissions after your proof is approved. Please note that production of this order will not start until all layouts are approved. Proofing is designed to reduce your final cost. Please examine carefully for any errors. Once approved, you are responsible for any and all cost to remake should any errors be found after production begins, no exceptions. You agree to these terms and art approval of the layouts by signing below.</small>	
Customer Approval	
Proof Approval	AD/CSC Production
QC Check	Ship: --/-- Install: --/--
Scale	Sheet
As Noted	CC.01

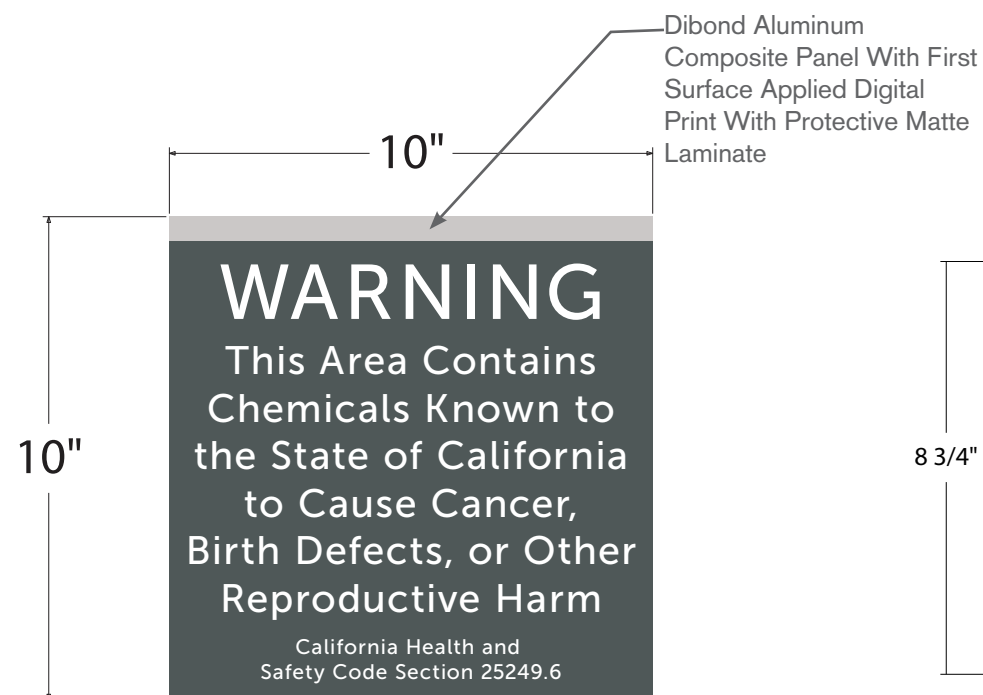

1 FRONT ELEVATION
DD.01 Scale: 2" = 1'

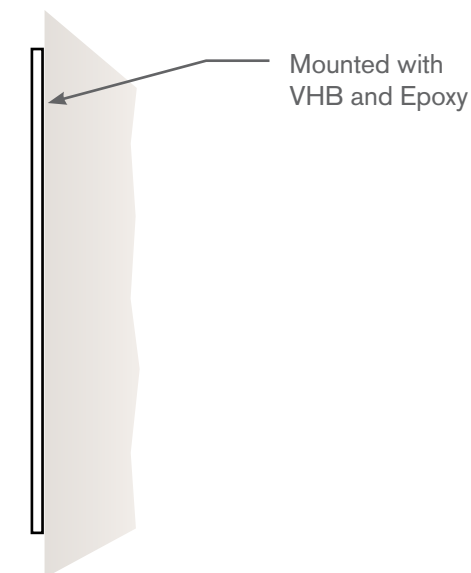
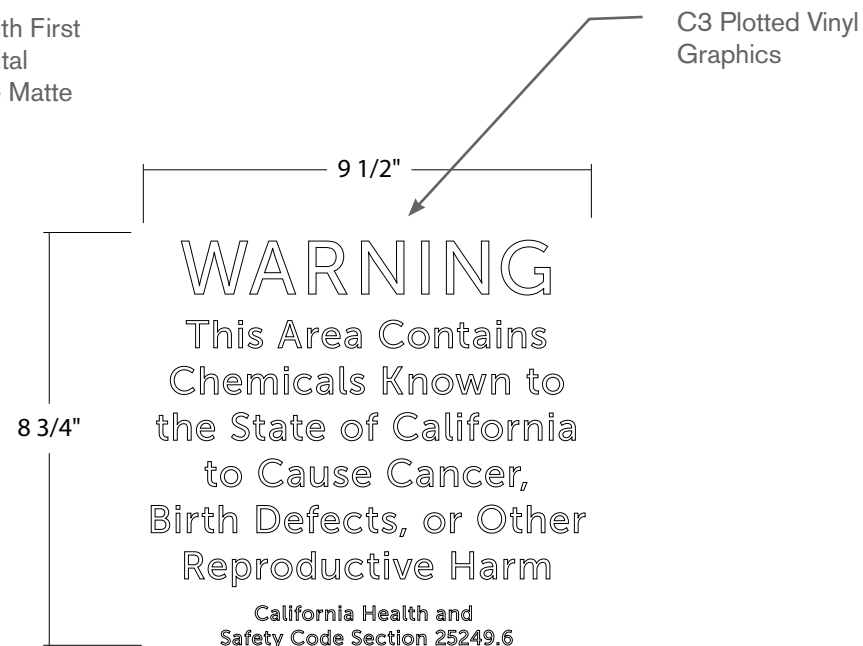

2 SIDE ELEVATION
DD.01 Scale: 2" = 1'

Notes

6195 Shiloh Road Suite A Alpharetta, GA 30005	
800-737-4434 yourbenson.com	
<small>Benson is a trade name of Benson Media, Inc. All ideas, designs and plans indicated or represented by this drawing are the property of Benson and were created and developed for use in connection with the specified project. They are not to be used, reproduced or copied in whole or in part and shall be returned upon request. None of such ideas, designs or plans shall be used by or disclosed to any persons, firms or corporations for any purpose whatsoever without the written consent of Benson. Copyright © Benson 2015. All rights reserved.</small>	
Client	
Essex	
Project	
Signage Master Proof	
Job Number	
246199	
Project Address	
Artist	Acct Director
M.Bando	K.Daniel
Colors & Finishes	
<small>Colors displayed in this PDF proof are a close representation, but may not be an accurate depiction of final printed/painted/fabricated product. Client to either provide samples or specifications or approve Benson color samples or specifications prior to production.</small>	
Modern Industrial	
[C1] PMS 445	[C2] PMS 420
[C3] White	[C4] Black
[C5] PMS	
<small>Benson is not responsible for errors or omissions after your proof is approved. Please note that production of this order will not start until all layouts are approved. Proofing is designed to reduce your final cost. Please examine carefully for any errors. Once approved, you are responsible for any and all cost to remake should any errors be found after production begins, no exceptions. You agree to these terms and art approval of the layouts by signing below.</small>	
Customer Approval	
Proof Approval	AD/CSC Production
QC Check	Ship: --/-- Install: --/--
Scale	Sheet
As Noted	DD.01

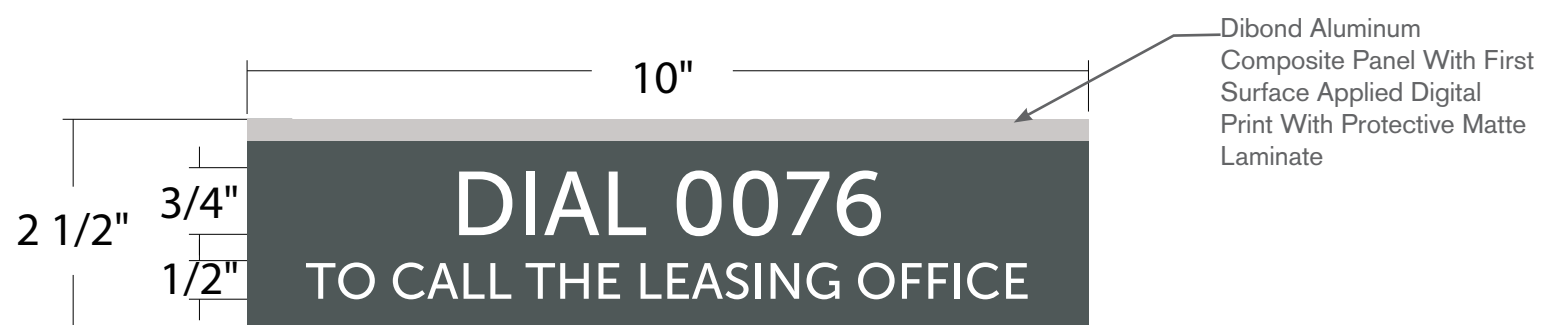

1 FRONT ELEVATION
EE.01 Scale: 2" = 1'

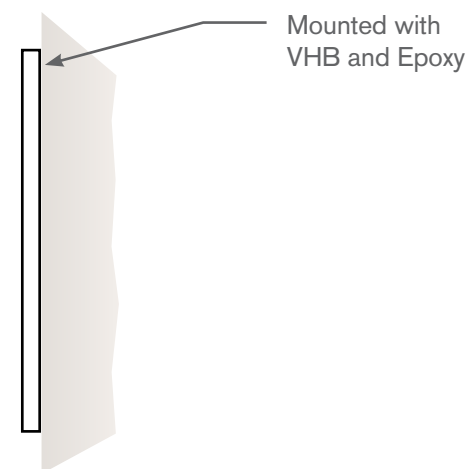

2 SIDE ELEVATION
EE.01 Scale: 2" = 1'

Notes

6195 Shiloh Road Suite A Alpharetta, GA 30005	
800-737-4434 yourbenson.com	
<small>Benson is a trade name of Benson Media, Inc. All ideas, designs and plans indicated or represented by this drawing are the property of Benson and were created and developed for use in connection with the specified project. They are not to be used, reproduced or copied in whole or in part and shall be returned upon request. None of such ideas, designs or plans shall be used by or disclosed to any persons, firms or corporations for any purpose whatsoever without the written consent of Benson. Copyright © Benson 2015. All rights reserved.</small>	
Client	
Essex	
Project	
Signage Master Proof	
Job Number	
246199	
Project Address	
Artist	Acct Director
M.Bando	K.Daniel
Colors & Finishes	
<small>Colors displayed in this PDF proof are a close representation, but may not be an accurate depiction of final printed/painted/fabricated product. Client to either provide samples or specifications or approve Benson color samples or specifications prior to production.</small>	
Modern Industrial	
[C1] PMS 445	[C2] PMS 420
[C3] White	[C4] Black
[C5] PMS	
<small>Benson is not responsible for errors or omissions after your proof is approved. Please note that production of this order will not start until all layouts are approved. Proofing is designed to reduce your final cost. Please examine carefully for any errors. Once approved, you are responsible for any and all cost to remake should any errors be found after production begins, no exceptions. You agree to these terms and art approval of the layouts by signing below.</small>	
Customer Approval	
Proof Approval	AD/CSC Production
QC Check	Ship: --/-- Install: --/--
Scale	Sheet
As Noted	EE.01

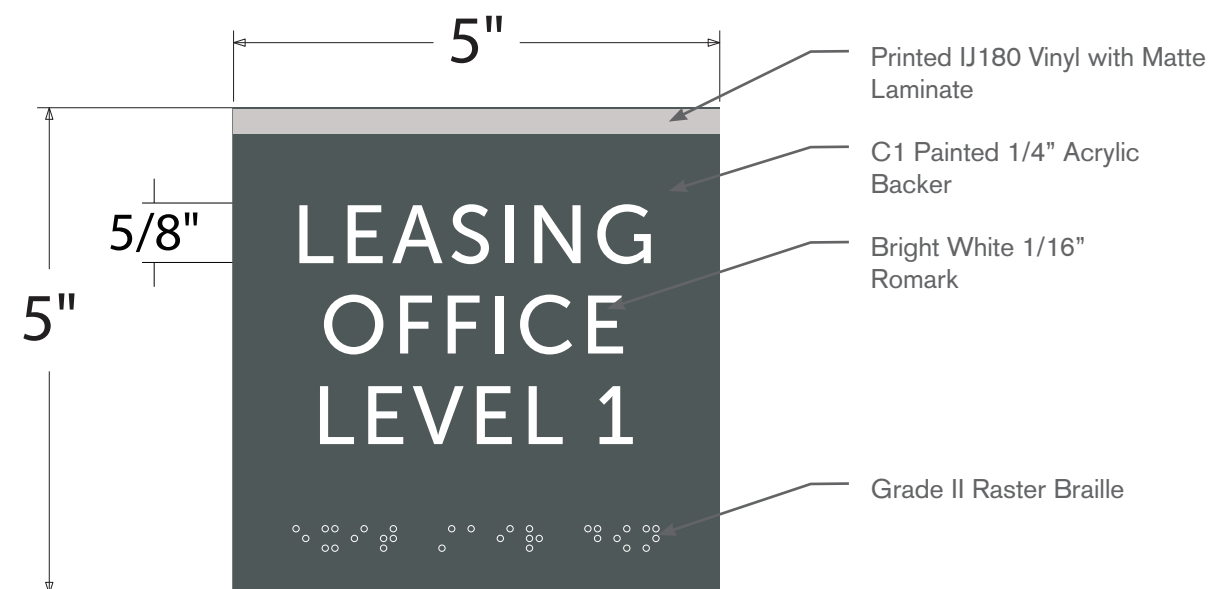

1 FRONT ELEVATION
FF.01 Scale: 6" = 1'

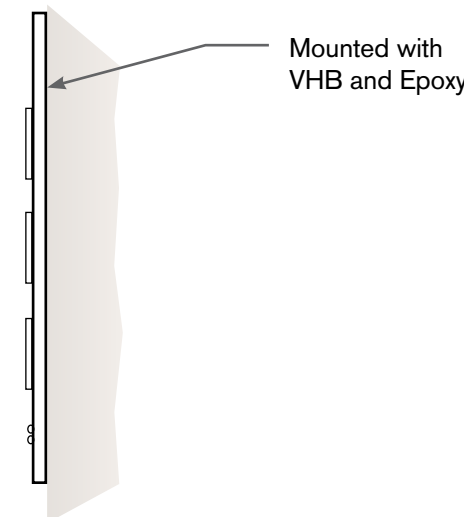

2 TYPICAL MOUNTING
FF.01 Scale: NTS

Notes

6195 Shiloh Road
Suite A
Alpharetta, GA 30005

800-737-4434
yourbenson.com

Benson is a trade name of Benson Media, Inc. All ideas, designs and plans indicated or represented by this drawing are the property of Benson and were created and developed for use in connection with the specified project. They are not to be used, reproduced or copied in whole or in part and shall be returned upon request. None of such ideas, designs or plans shall be used by or disclosed to any persons, firms or corporations for any purpose whatsoever without the written consent of Benson. Copyright © Benson 2015. All rights reserved.

Client

Essex

Project

Signage Master Proof

Job Number

246199

Project Address

Artist **Acct Director**

M.Bando K.Daniel

Colors & Finishes

Colors displayed in this PDF proof are a close representation, but may not be an accurate depiction of final printed/painted/fabricated product. Client to either provide samples or specifications or approve Benson color samples or specifications prior to production.

Modern Industrial

[C1] PMS 445	[C2] PMS 420	[C3] White
[C4] Black	[C5] PMS	

Benson is not responsible for errors or omissions after your proof is approved. Please note that production of this order will not start until all layouts are approved. Proofing is designed to reduce your final cost. Please examine carefully for any errors. Once approved, you are responsible for any and all cost to remake should any errors be found after production begins, no exceptions. You agree to these terms and art approval of the layouts by signing below.

Customer Approval		
Proof Approval	AD/CSC	Production
QC Check		Ship: --/-- Install: --/--
Scale	Sheet	
As Noted	FF.01	

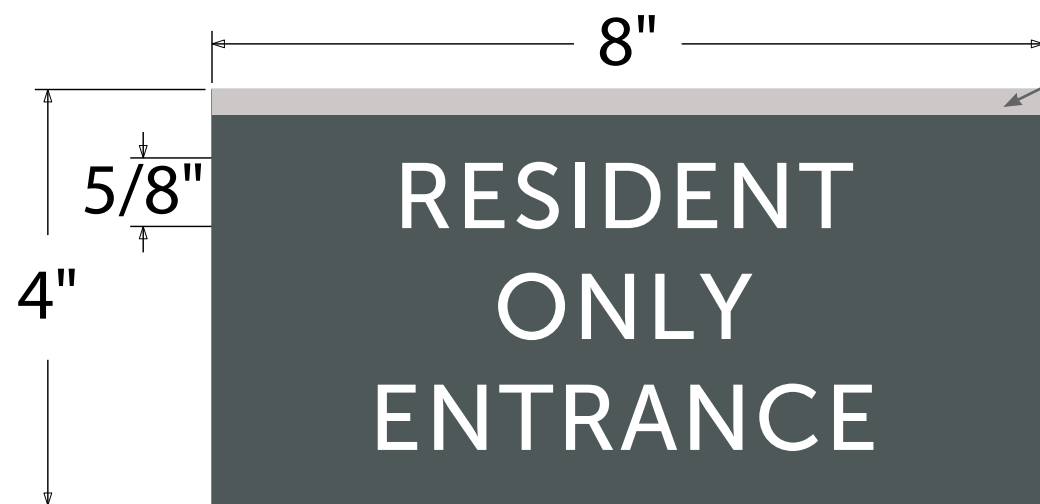

Dibond Aluminum Composite Panel With First Surface Applied Digital Print With Protective Matte Laminate

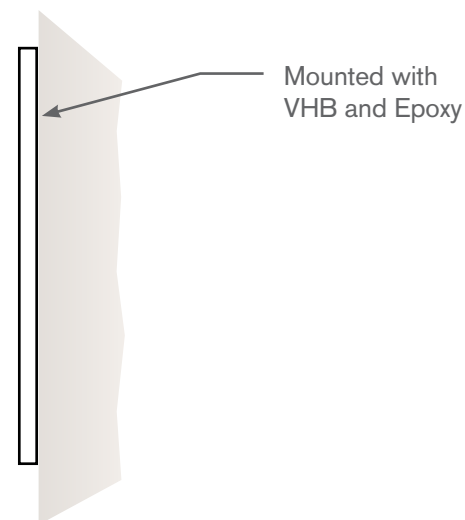

Mounted with VHB and Epoxy

1 FRONT ELEVATION
GG.01 Scale: 2" = 1'

2 SIDE ELEVATION
GG.01 Scale: 2" = 1'

Notes

6195 Shiloh Road
Suite A
Alpharetta, GA 30005

800-737-4434
yourbenson.com

Benson is a trade name of Benson Media, Inc. All ideas, designs and plans indicated or represented by this drawing are the property of Benson and were created and developed for use in connection with the specified project. They are not to be used, reproduced or copied in whole or in part and shall be returned upon request. None of such ideas, designs or plans shall be used by or disclosed to any persons, firms or corporations for any purpose whatsoever without the written consent of Benson. Copyright © Benson 2015. All rights reserved.

Client	
Essex	
Project	
Signage Master Proof	
Job Number	
246199	
Project Address	
Artist	Acct Director
M.Bando	K.Daniel

Colors & Finishes

Colors displayed in this PDF proof are a close representation, but may not be an accurate depiction of final printed/painted/fabricated product. Client to either provide samples or specifications or approve Benson color samples or specifications prior to production.

Modern Industrial

[C1] PMS 445	[C2] PMS 420	[C3] White
[C4] Black	[C5] PMS	

Benson is not responsible for errors or omissions after your proof is approved. Please note that production of this order will not start until all layouts are approved. Proofing is designed to reduce your final cost. Please examine carefully for any errors. Once approved, you are responsible for any and all cost to remake should any errors be found after production begins, no exceptions. You agree to these terms and art approval of the layouts by signing below.

Customer Approval		
Proof Approval	AD/CSC	Production
QC Check		Ship: --/-- Install: --/--
Scale	Sheet	
As Noted	GG.01	

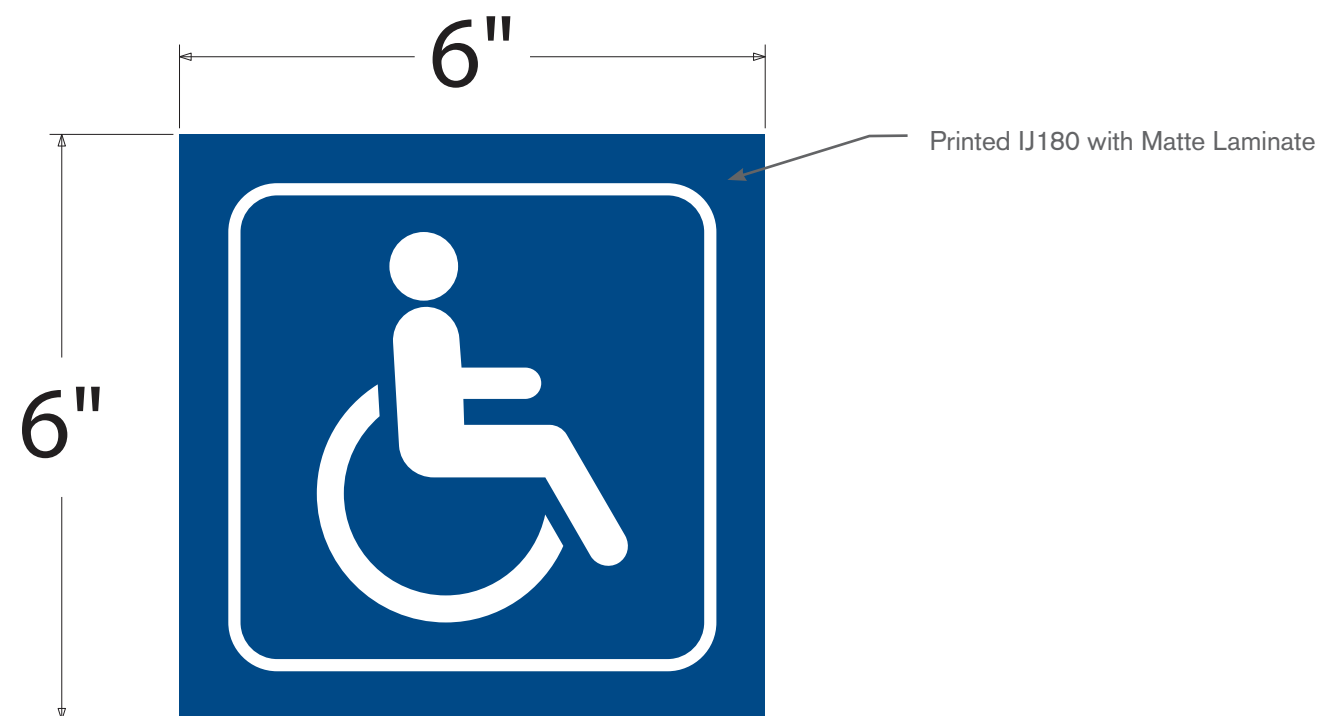

1 FRONT ELEVATION
HH.01 Scale: 6" = 1'

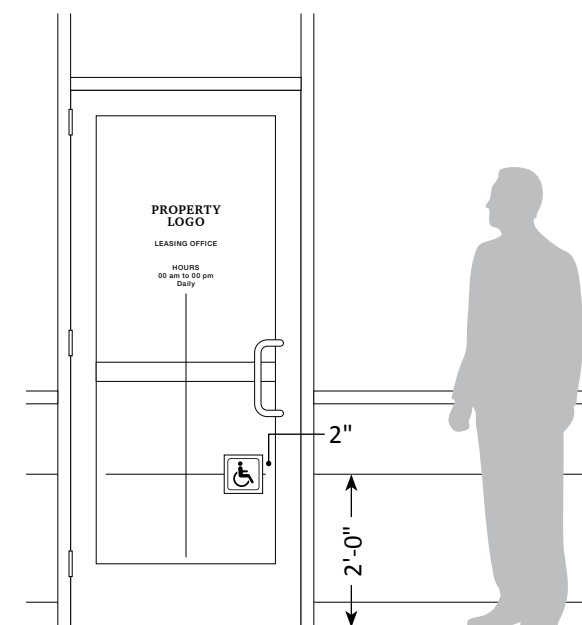

2 MOUNTING
HH.01 Scale: NTS

Notes

6195 Shiloh Road
Suite A
Alpharetta, GA 30005

800-737-4434
yourbenson.com

Benson is a trade name of Benson Media, Inc. All ideas, designs and plans indicated or represented by this drawing are the property of Benson and were created and developed for use in connection with the specified project. They are not to be used, reproduced or copied in whole or in part and shall be returned upon request. None of such ideas, designs or plans shall be used by or disclosed to any persons, firms or corporations for any purpose whatsoever without the written consent of Benson. Copyright © Benson 2015. All rights reserved.

Client

Essex

Project

Signage Master Proof

Job Number

246199

Project Address

Artist **Acct Director**

M.Bando K.Daniel

Colors & Finishes

Colors displayed in this PDF proof are a close representation, but may not be an accurate depiction of final printed/painted/fabricated product. Client to either provide samples or specifications or approve Benson color samples or specifications prior to production.

Modern Industrial

[C1] PMS 445	[C2] PMS 420	[C3] White
[C4] Black	[C5] PMS	

Benson is not responsible for errors or omissions after your proof is approved. Please note that production of this order will not start until all layouts are approved. Proofing is designed to reduce your final cost. Please examine carefully for any errors. Once approved, you are responsible for any and all cost to remake should any errors be found after production begins, no exceptions. You agree to these terms and art approval of the layouts by signing below.

Customer Approval

Proof Approval	AD/CSC	Production
QC Check		Ship: --/-- Install: --/--

Scale	Sheet
As Noted	HH.01

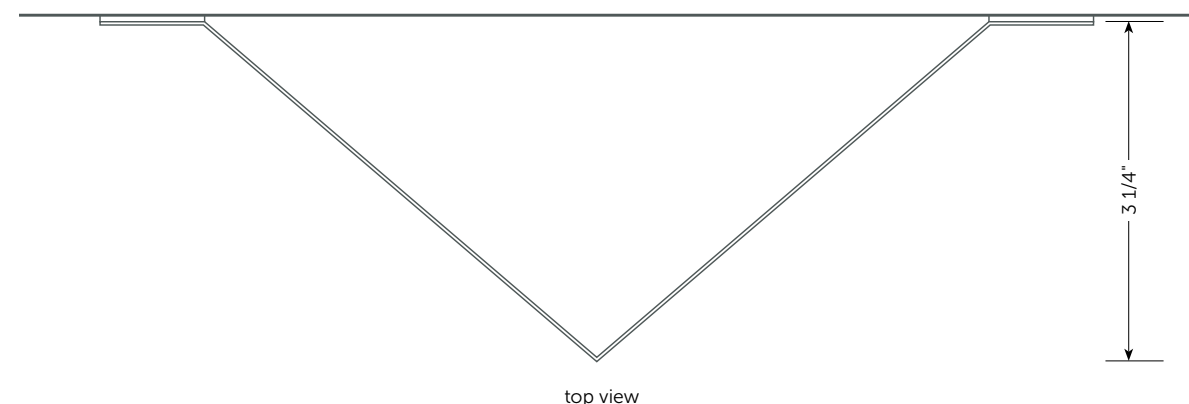

Dibond Aluminum Composite Panel With First Surface Applied Digital Print With Protective Matte Laminate

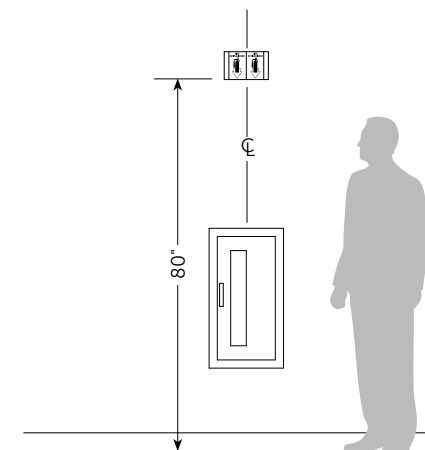
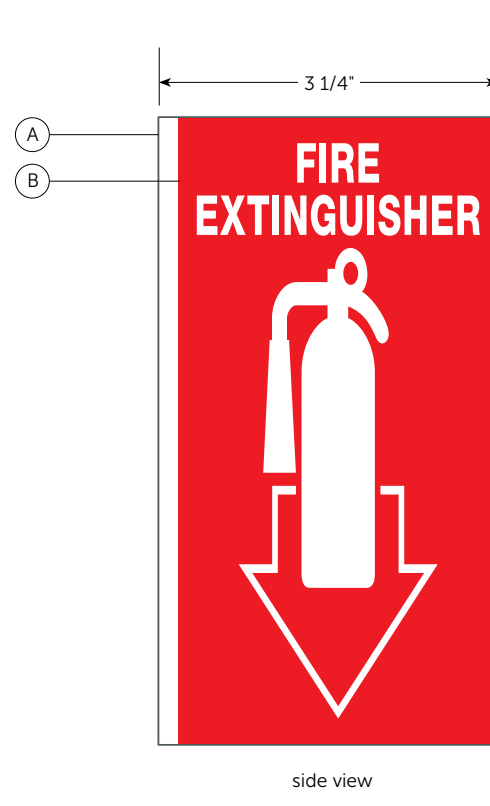
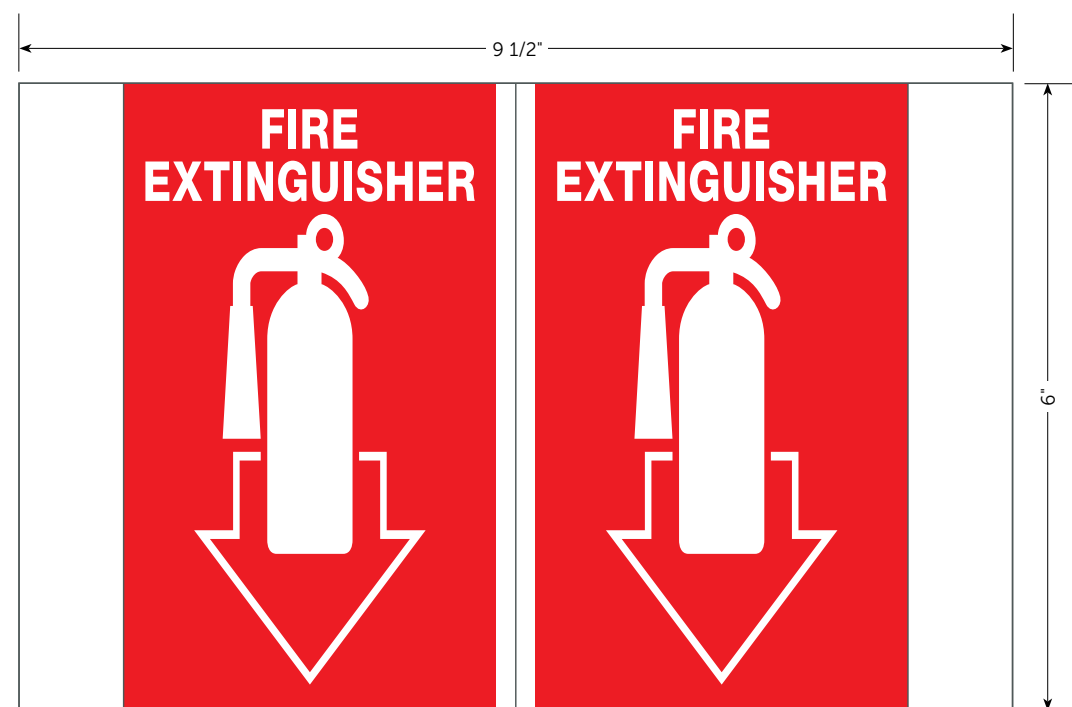

1 FRONT ELEVATION
II.01 Scale: 3" = 1'

Notes

6195 Shiloh Road
Suite A
Alpharetta, GA 30005

800-737-4434
yourbenson.com

Benson is a trade name of Benson Media, Inc. All ideas, designs and plans indicated or represented by this drawing are the property of Benson and were created and developed for use in connection with the specified project. They are not to be used, reproduced or copied in whole or in part and shall be returned upon request. None of such ideas, designs or plans shall be used by or disclosed to any persons, firms or corporations for any purpose whatsoever without the written consent of Benson. Copyright © Benson 2015. All rights reserved.

Client	
Essex	
Project	
Signage Master Proof	
Job Number	
246199	
Project Address	
Artist	Acct Director
M.Bando	K.Daniel

Colors & Finishes
Colors displayed in this PDF proof are a close representation, but may not be an accurate depiction of final printed/painted/fabricated product. Client to either provide samples or specifications or approve Benson color samples or specifications prior to production.

Modern Industrial

[C1] PMS 445	[C2] PMS 420	[C3] White
[C4] Black	[C5] PMS	

Benson is not responsible for errors or omissions after your proof is approved. Please note that production of this order will not start until all layouts are approved. Proofing is designed to reduce your final cost. Please examine carefully for any errors. Once approved, you are responsible for any and all cost to remake should any errors be found after production begins, no exceptions. You agree to these terms and art approval of the layouts by signing below.

Customer Approval		
Proof Approval	AD/CSC	Production
QC Check		Ship: --/-- Install: --/--
Scale		Sheet
As Noted		II.01



DOT Panel with Reflective Graphics

**DOT HANDICAP SIGN
PULLED FROM STATE'S
REQUIREMENTS**

1 FRONT ELEVATION
JJ.01 Scale: 3" = 1'

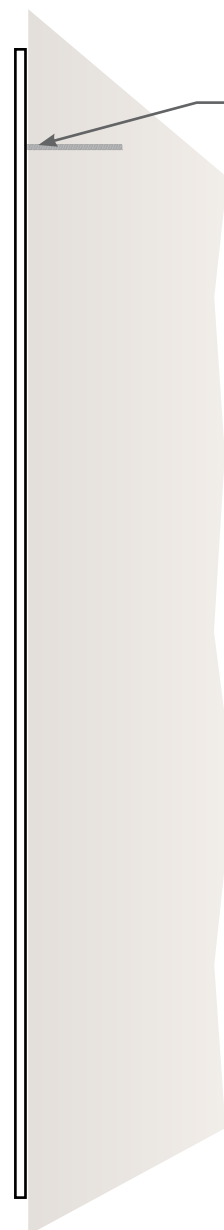

Mounted with 1-1/2" Studs, VHB and Epoxy

2 SIDE ELEVATION
JJ.01 Scale: 3" = 1'

Notes

DOT Handicap will be pulled from specific state's requirements. Mounting varies.

6195 Shiloh Road Suite A Alpharetta, GA 30005	
800-737-4434 yourbenson.com	
<small>Benson is a trade name of Benson Media, Inc. All ideas, designs and plans indicated or represented by this drawing are the property of Benson and were created and developed for use in connection with the specified project. They are not to be used, reproduced or copied in whole or in part and shall be returned upon request. None of such ideas, designs or plans shall be used by or disclosed to any persons, firms or corporations for any purpose whatsoever without the written consent of Benson. Copyright © Benson 2015. All rights reserved.</small>	
Client	
Essex	
Project	
Signage Master Proof	
Job Number	
246199	
Project Address	
Artist	Acct Director
M.Bando	K.Daniel
Colors & Finishes	
<small>Colors displayed in this PDF proof are a close representation, but may not be an accurate depiction of final printed/painted/fabricated product. Client to either provide samples or specifications or approve Benson color samples or specifications prior to production.</small>	
Modern Industrial	
[C1] PMS 445	[C2] PMS 420
[C3] White	[C4] Black
[C5] PMS	
<small>Benson is not responsible for errors or omissions after your proof is approved. Please note that production of this order will not start until all layouts are approved. Proofing is designed to reduce your final cost. Please examine carefully for any errors. Once approved, you are responsible for any and all cost to remake should any errors be found after production begins, no exceptions. You agree to these terms and art approval of the layouts by signing below.</small>	
Customer Approval	
Proof Approval	AD/CSC Production
QC Check	Ship: --/-- Install: --/--
Scale	Sheet
As Noted	JJ.01

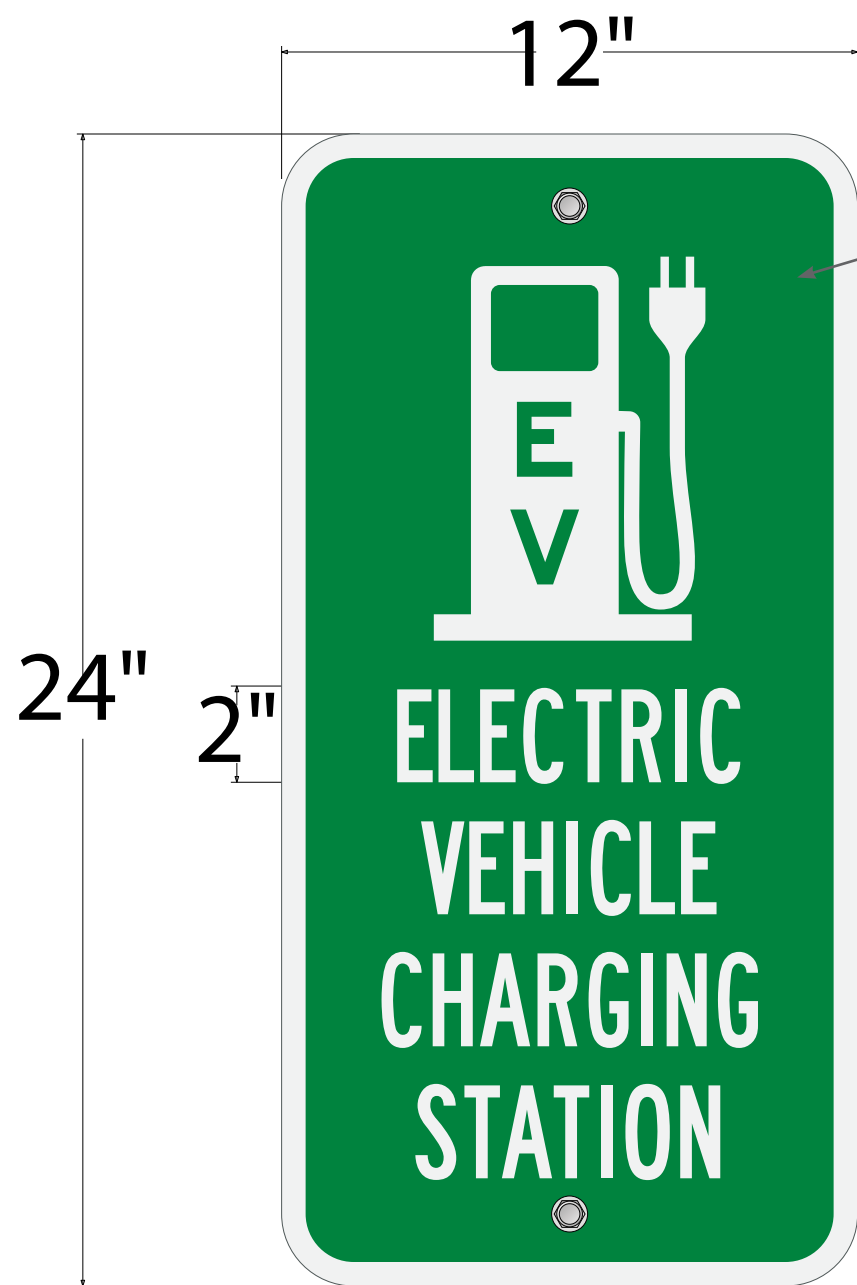

DOT Panel with Reflective Graphics

1 FRONT ELEVATION
KK.01 Scale: 3" = 1'

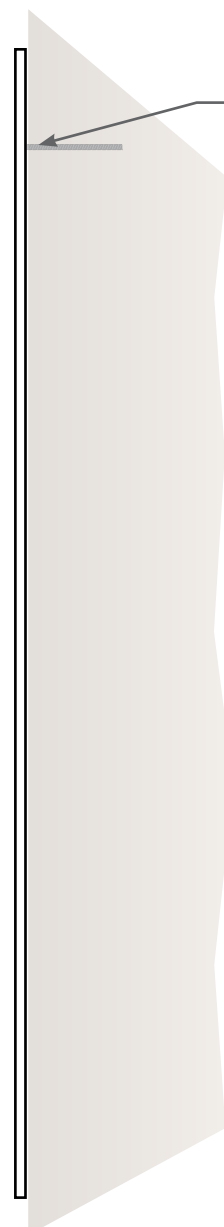

Mounted with 1-1/2" Studs, VHB and Epoxy

2 SIDE ELEVATION
KK.01 Scale: 3" = 1'

Notes

Mounting varies.

6195 Shiloh Road Suite A Alpharetta, GA 30005	
800-737-4434 yourbenson.com	
<small>Benson is a trade name of Benson Media, Inc. All ideas, designs and plans indicated or represented by this drawing are the property of Benson and were created and developed for use in connection with the specified project. They are not to be used, reproduced or copied in whole or in part and shall be returned upon request. None of such ideas, designs or plans shall be used by or disclosed to any persons, firms or corporations for any purpose whatsoever without the written consent of Benson. Copyright © Benson 2015. All rights reserved.</small>	
Client	
Essex	
Project	
Signage Master Proof	
Job Number	
246199	
Project Address	
Artist	Acct Director
M.Bando	K.Daniel
Colors & Finishes	
<small>Colors displayed in this PDF proof are a close representation, but may not be an accurate depiction of final printed/painted/fabricated product. Client to either provide samples or specifications or approve Benson color samples or specifications prior to production.</small>	
Modern Industrial	
[C1] PMS 445	[C2] PMS 420
[C3] White	[C4] Black
[C5] PMS	
<small>Benson is not responsible for errors or omissions after your proof is approved. Please note that production of this order will not start until all layouts are approved. Proofing is designed to reduce your final cost. Please examine carefully for any errors. Once approved, you are responsible for any and all cost to remake should any errors be found after production begins, no exceptions. You agree to these terms and art approval of the layouts by signing below.</small>	
Customer Approval	
Proof Approval	AD/CSC Production
QC Check	Ship: --/-- Install: --/--
Scale	Sheet
As Noted	KK.01

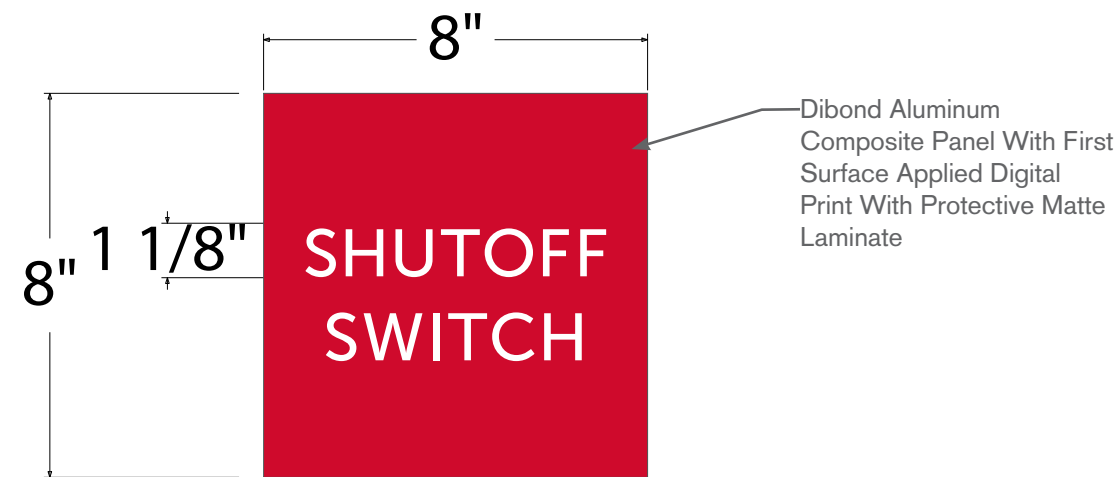

1 FRONT ELEVATION
LL.01 Scale: 3" = 1'

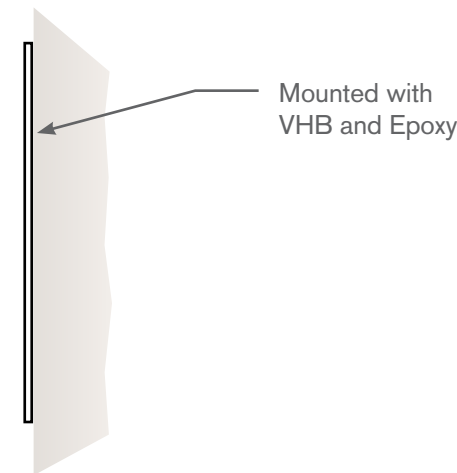

2 SIDE ELEVATION
LL.01 Scale: 3" = 1'

Notes

6195 Shiloh Road
Suite A
Alpharetta, GA 30005

800-737-4434
yourbenson.com

Benson is a trade name of Benson Media, Inc. All ideas, designs and plans indicated or represented by this drawing are the property of Benson and were created and developed for use in connection with the specified project. They are not to be used, reproduced or copied in whole or in part and shall be returned upon request. None of such ideas, designs or plans shall be used by or disclosed to any persons, firms or corporations for any purpose whatsoever without the written consent of Benson. Copyright © Benson 2015. All rights reserved.

Client

Essex

Project

Signage Master Proof

Job Number

246199

Project Address

Artist **Acct Director**

M.Bando K.Daniel

Colors & Finishes

Colors displayed in this PDF proof are a close representation, but may not be an accurate depiction of final printed/painted/fabricated product. Client to either provide samples or specifications or approve Benson color samples or specifications prior to production.

Modern Industrial

[C1]	[C2]	[C3]
PMS 445	PMS 420	White
[C4]	[C5]	
Black	PMS	

Benson is not responsible for errors or omissions after your proof is approved. Please note that production of this order will not start until all layouts are approved. Proofing is designed to reduce your final cost. Please examine carefully for any errors. Once approved, you are responsible for any and all cost to remake should any errors be found after production begins, no exceptions. You agree to these terms and art approval of the layouts by signing below.

Customer Approval

Proof Approval	AD/CSC	Production
QC Check		Ship: --/-- Install: --/--

Scale	Sheet
As Noted	LL.01